



®

GENERATION FUTURE

# ÁLYX



## USER INSTRUCTIONS

(1)

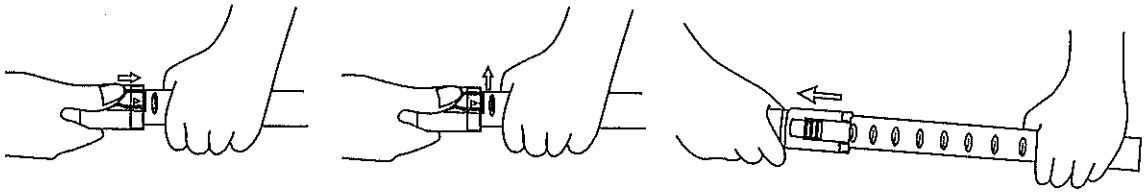

(2)

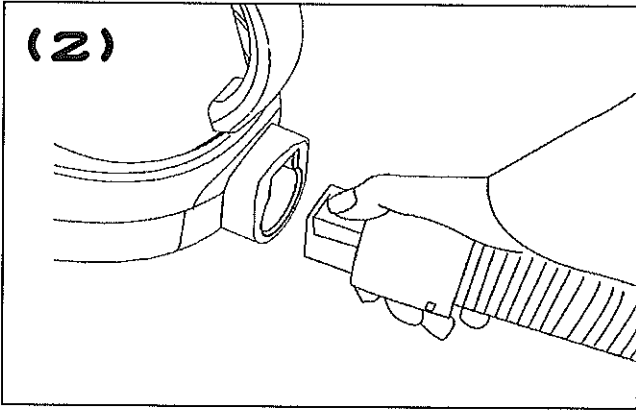

(3)

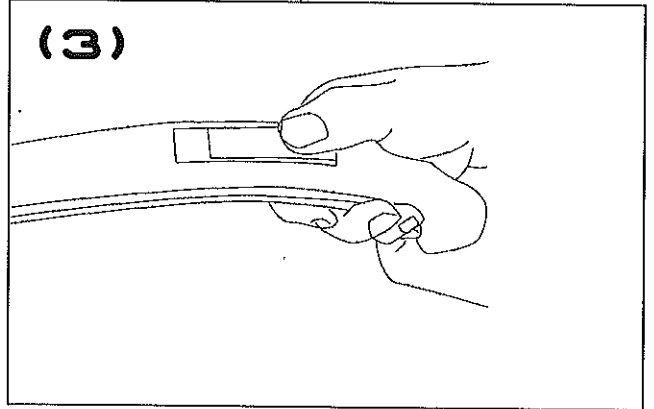

(4)

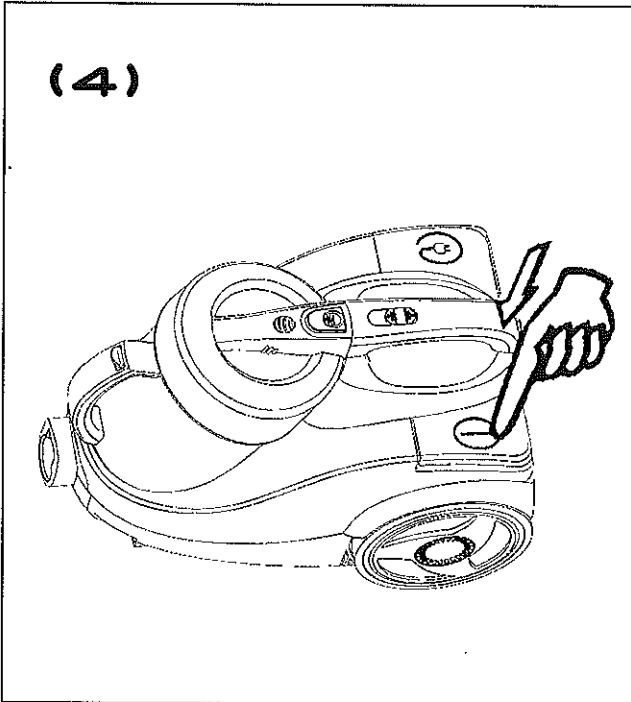

(5)

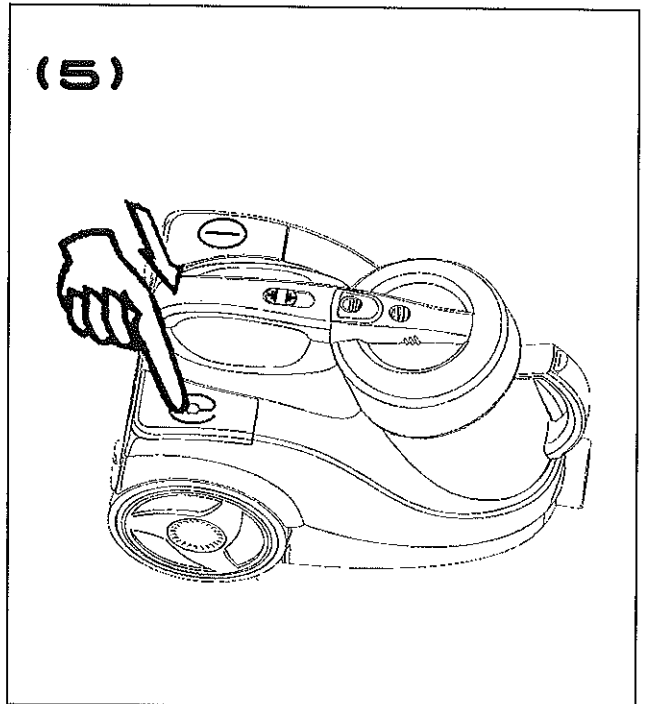

(6) \*

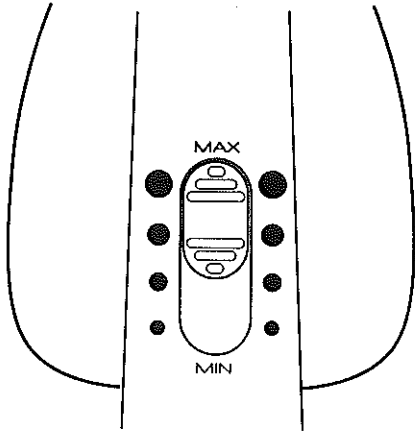

(7)

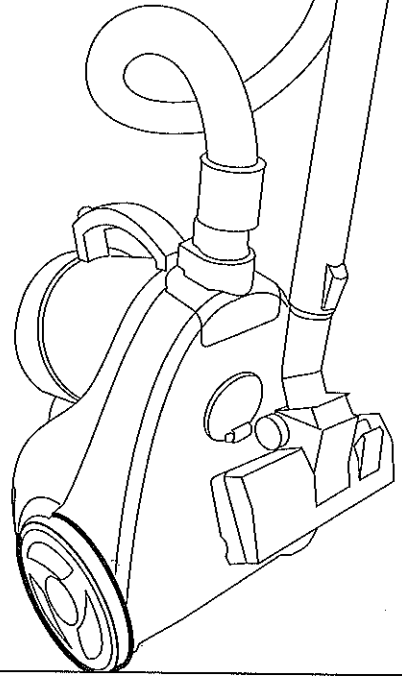

(8)

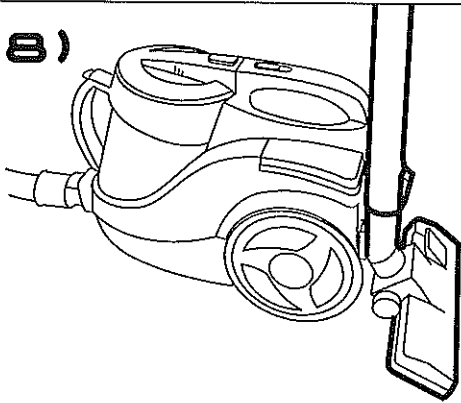

(9)

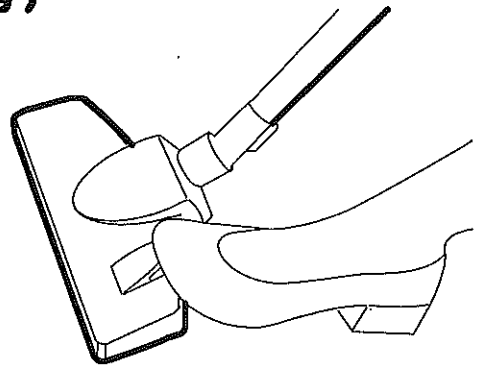

(10)

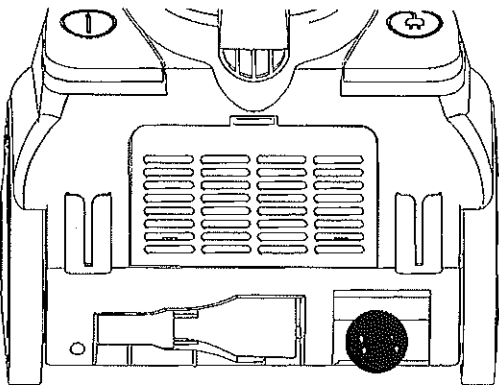

(11A)

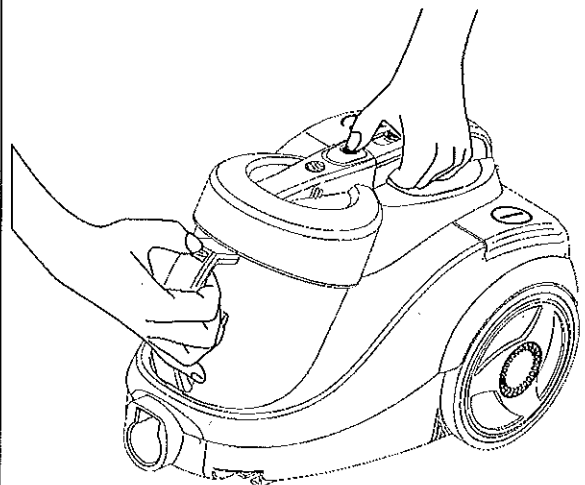

# ENGLISH

## ELECTRICAL REQUIREMENTS

### WARNING!

**ELECTRICITY CAN BE EXTREMELY DANGEROUS.**

THIS APPLIANCE IS DOUBLE INSULATED AND MUST NOT BE EARTHED.

IMPORTANT: THE WIRES IN THE MAINS LEAD ARE COLOURED IN ACCORDANCE WITH THE FOLLOWING CODE:

BLUE - NEUTRAL

BROWN - LIVE

\*FEATURE VARIES ACCORDING TO MODEL

POWER CONTROL (6) \* *on TC1192*

TELESCOPIC TUBES (1) \*

PUSH THE LATCH FORWARDS TO UNLOCK TUBES. PULL OUT TO REQUIRED LENGTH. RELEASE THE LATCH TO LOCK.

MOVE SLIDE CONTROL TO SET POWER LEVEL.

HOSE FITTING (2)

PUSH INTO HOSE INLET, UNTIL HOSE LATCH LOCKS. TO RELEASE, PRESS THE LATCH AND PULL OUT.

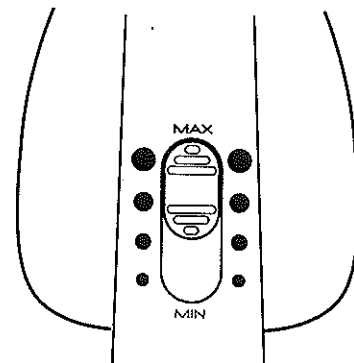

SUCTION REGULATOR (3)

MOVE SLIDER TO ADJUST SUCTION.

STORING THE CLEANER (7)

USE STORAGE CLIP AS SHOWN WHEN STORING THE CLEANER.

ON/OFF PEDAL (4)

PUSH TO SWITCH ON.

PUSH AGAIN TO SWITCH OFF.

PARK POSITION (8)

FOR TEMPORARY STORAGE DURING CLEANING.

CORD REEL PEDAL (5)

PUSH TO AUTOMATICALLY REEL IN SUPPLY CORD.

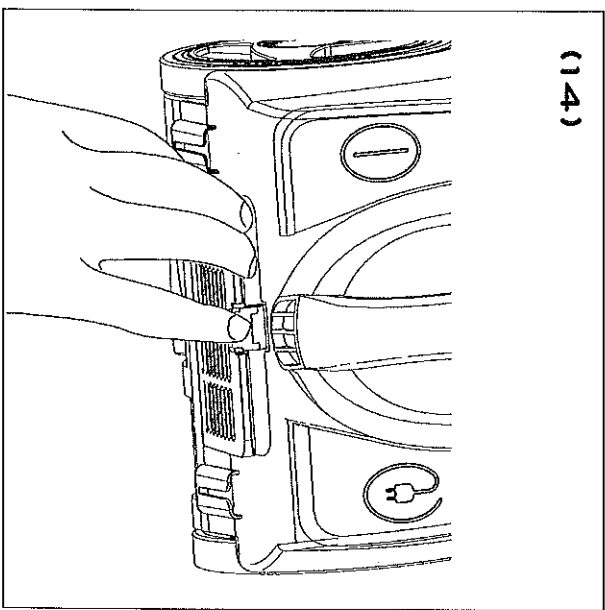
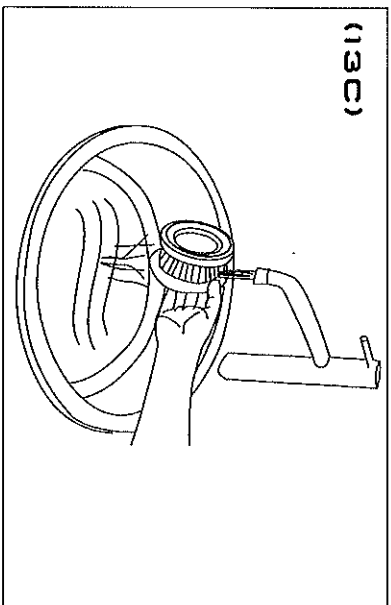
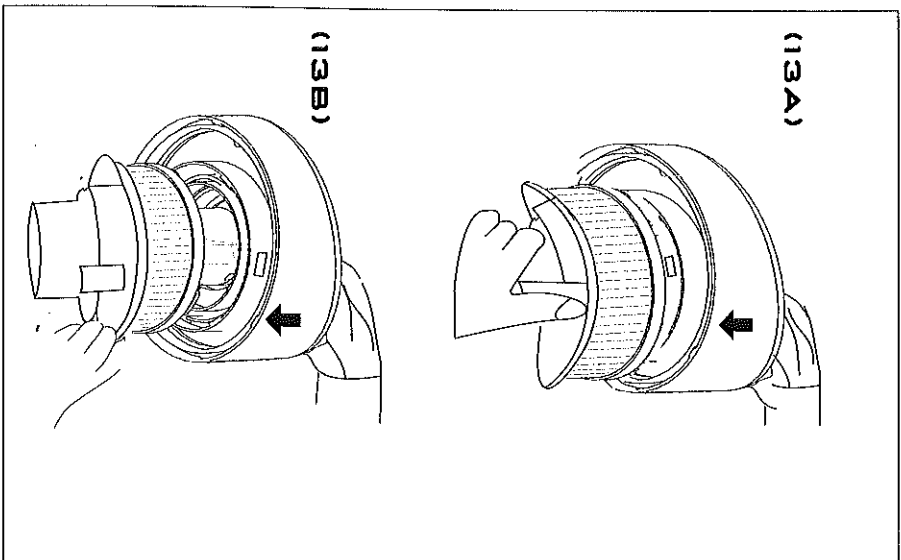
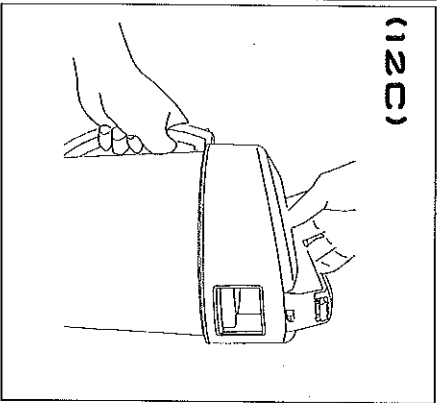
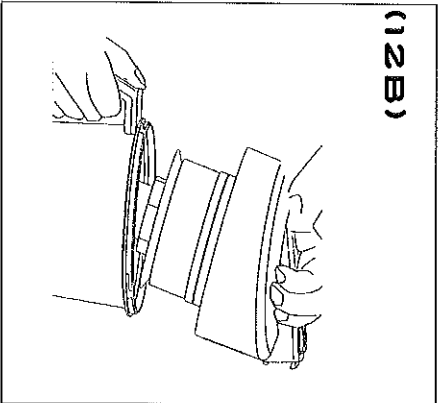
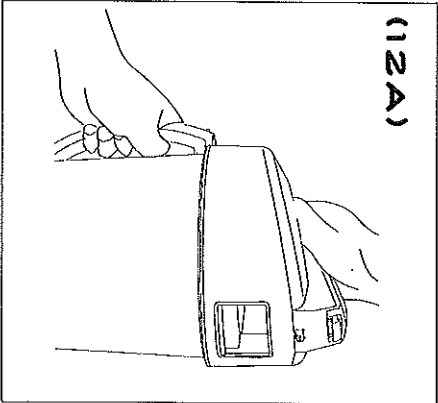
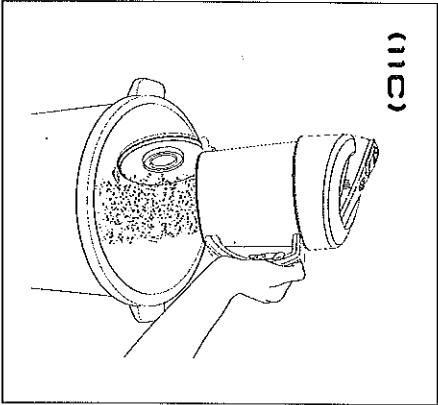
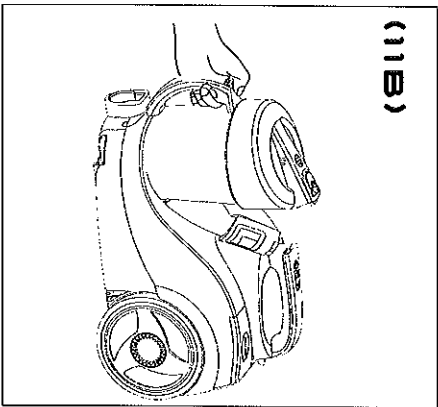

# ENGLISH

## PLEASE READ THESE INSTRUCTIONS THOROUGHLY

THIS PRODUCT MUST BE ASSEMBLED AND OPERATED IN ACCORDANCE WITH THESE INSTRUCTIONS AND USED ONLY FOR DOMESTIC CLEANING TO REMOVE DRY DIRT AND DUST FROM HOUSEHOLD CARPETS AND FLOORING.

THE TOOL KIT CAN BE USED TO REMOVE DIRT AND DUST FROM FURNITURE AND FABRICS.

## SAFETY REMINDERS

**USER'S MANUAL.** THIS CLEANER SHOULD ONLY BE USED FOR ITS INTENDED PURPOSE AS DESCRIBED IN THESE INSTRUCTIONS. ENSURE THAT THESE ARE FULLY UNDERSTOOD BEFORE OPERATING THE APPLIANCE.

**MAINTAIN THE FILTERS** FREQUENTLY WHEN PICKING UP MATERIAL SUCH AS POWDER OR FINE DUST OR WHEN CLEANING NEW CARPETS.

**DO NOT** USE YOUR CLEANER OUT OF DOORS OR ON ANY WET SURFACE OR FOR WET PICK-UP.

**DO NOT** PICK UP HARD OR SHARP OBJECTS, MATCHES, HOT ASHES, CIGARETTE ENDS OR OTHER SIMILAR ITEMS.

**STATIC ELECTRICITY.** SOME CARPETS CAN CAUSE A SMALL BUILD UP OF STATIC ELECTRICITY. ANY STATIC DISCHARGE IS NOT HAZARDOUS TO HEALTH.

**ONLY** USE ATTACHMENTS RECOMMENDED OR SUPPLIED BY HOOVER.

**DO NOT** PICK UP FLAMMABLE LIQUIDS SUCH AS CLEANING FLUIDS, PETROL ETC, OR THEIR VAPOURS.

**AEROSOL SPRAYS** MAY BE FLAMMABLE. DO NOT SPRAY NEAR THE CLEANER.

**SUPPLY CORD.** DO NOT REMOVE THE PLUG BY PULLING ON THE SUPPLY CORD. IF THE SUPPLY CORD IS DAMAGED, THE CLEANER MUST BE REPAIRED BY AN AUTHORISED HOOVER SERVICE ENGINEER TO AVOID A SAFETY HAZARD.

**FAULTS.** DO NOT CONTINUE TO USE YOUR CLEANER IF IT APPEARS TO BE FAULTY OR THE SUPPLY CORD IS DAMAGED.

**AFTER USE.** SWITCH THE CLEANER OFF AND REMOVE THE PLUG FROM THE ELECTRICITY SUPPLY. ALWAYS SWITCH OFF AND REMOVE THE PLUG BEFORE CLEANING THE APPLIANCE OR ATTEMPTING ANY MAINTENANCE WORK.

**HOOVER SERVICE.** TO ENSURE THE CONTINUED SAFE AND EFFICIENT OPERATION OF THIS APPLIANCE, WE RECOMMEND THAT ANY SERVICING OR REPAIRS ARE ONLY CARRIED OUT BY AN AUTHORISED HOOVER SERVICE ENGINEER.

# ENGLISH

## CARPET/FLOOR NOZZLE (9)

- A) CARPET POSITION - BRUSHES IN
- B) HARD FLOOR POSITION - BRUSHES OUT

## CLEANING TOOLS (10)

A MULTI CLEANING TOOL IS SUPPLIED WITH YOUR PRODUCT. THIS TOOL IS STORED ON BOARD THE CLEANER AS SHOWN.

THE MULTI TOOL BRUSHES CAN BE DEPLOYED TO CREATE A DUSTING BRUSH.

## EMPTYING AND CLEANING DUST CONTAINER AND FILTER

**IMPORTANT: SWITCH CLEANER OFF AND REMOVE PLUG FROM ELECTRICITY SUPPLY BEFORE EMPTYING DUST CONTAINER OR REMOVING ANY FILTERS**

**DO NOT** USE THE CLEANER WITHOUT THE DUST CONTAINER OR FILTERS IN PLACE.

### EMPTYING THE DUST CONTAINER (11)

FOR OPTIMUM PERFORMANCE HOOVER RECOMMENDS THAT YOU EMOTY THE DUST CONTAINER AFTER EACH USE.

TO EMPTY THE DUST CONTAINER:

- PUSH THE RELEASE BUTTON ON THE DUST CONTAINER TOP. (11A)
- LIFT OUT THE DUST CONTAINER USING THE CARRY HANDLE. (11B)
- POSITION THE DUST CONTAINER OVER A BIN BEFORE OPENING
- PRESS THE LATCH ON THE HANDLE TO OPEN THE DUST CONTAINER DOOR AND DISPOSE OF THE DUST. (11C)
- CLOSE DUST CONTAINER DOOR AND REFIT THE CONTAINER IN ITS ORIGINAL POSITION IN THE CLEANER.

## ACCESSING THE HEPA PRE MOTOR FILTER (12)

IN ORDER TO ACCESS THE HEPA PRE MOTOR FILTER, FOLLOW THESE STEPS.

- REMOVE THE DUST CONTAINER FROM THE CLEANER
- WHILE HOLDING THE DUST CONTAINER HANDLE, GRIP THE TOP COVER.
- ROTATE THE TOP COVER ANTICLOCKWISE TO THE UNLOCKED POSITION AND REMOVE FROM THE DUST CONTAINER. (12A, B)

## MAINTAINING THE HEPA PRE MOTOR FILTER (13)

HOOVER RECOMMENDS THAT YOU WASH THE FILTER AFTER FIVE CONTAINER EMPTIES.

- REMOVE THE HEPA PRE-MOTOR FILTER BY ROTATING IT CLOCKWISE
- TAP THE HEPA PRE-MOTOR FILTER OVER A BIN
- RINSE UNDER HAND WARM WATER, IF NECESSARY (13C)
- LEAVE TO DRY FOR 24 HOURS OR UNTIL COMPLETELY DRY BEFORE REFITTING
- REFIT FILTER BY ALIGNING THE FILTER LOCKING FEATURES TO THE LOCATIONS IN THE COVER AND ROTATING THE FILTER ANTI-CLOCKWISE UNTIL LOCKED

**IMPORTANT: NEVER USE THE CLEANER WITHOUT PRE-MOTOR FILTER FITTED**

### CHANGING THE EXHAUST FILTER (14)

HOOVER RECOMMENDS THAT YOU REPLACE THE EXHAUST FILTER EVERY 3 MONTHS.

- PRESS THE EXHAUST FILTER GRID LATCH TO GAIN ACCESS TO THE EXHAUST FILTER
- REMOVE THE FILTER
- FIT NEW FILTER AND REFIT THE COVER IN ITS ORIGINAL POSITION.

# ENGLISH

## CALLING FOR SERVICE

A CHARGE WILL BE MADE IF THE CLEANER IS FOUND TO BE IN WORKING ORDER OR HAS NOT BEEN ASSEMBLED IN ACCORDANCE WITH THESE INSTRUCTIONS OR HAS BEEN USED INCORRECTLY.

BEFORE CALLING A HOOVER SERVICE ENGINEER RUN THROUGH THE FOLLOWING CHECKLIST:

1. IS THERE A WORKING ELECTRICITY SUPPLY TO THE CLEANER?  
CHECK WITH ANOTHER APPLIANCE.
2. IS THE DUST CONTAINER FULL?
3. IS THE HOSE BLOCKED?
4. ARE THE FILTERS BLOCKED?

IF THERE IS ANY DOUBT CALL YOUR LOCAL HOOVER SERVICE OFFICE FOR ADVICE, THEY MAY BE ABLE TO ASSIST YOU OVER THE TELEPHONE.

## GUARANTEE STATEMENT

THE GUARANTEE CONDITIONS FOR THIS APPLIANCE ARE AS DEFINED BY OUR REPRESENTATIVE IN THE COUNTRY IN WHICH IT IS SOLD. DETAILS REGARDING THESE CONDITIONS CAN BE OBTAINED FROM THE DEALER FROM WHOM THE APPLIANCE WAS PURCHASED. THE BILL OF SALE OR RECEIPT MUST BE PRODUCED WHEN MAKING ANY CLAIM UNDER THE TERMS OF THIS GUARANTEE.

SUBJECT TO CHANGE WITHOUT NOTICE.

GIAS CUSTOMER SERVICE 08705 400600

HOOVER SPARES 01204 556111

## ENVIRONMENT

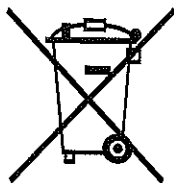

THIS APPLIANCE IS MARKED ACCORDING TO THE EUROPEAN DIRECTIVE 2002/96/EC ON THE WASTE OF ELECTRICAL AND ELECTRONIC EQUIPMENT (WEEE). BY ENSURING THIS PRODUCT IS DISPOSED OF CORRECTLY, YOU WILL HELP PREVENT POTENTIAL NEGATIVE CONSEQUENCES FOR THE ENVIRONMENT AND HUMAN HEALTH, WHICH COULD OTHERWISE BE CAUSED BY INAPPROPRIATE WASTE HANDLING OF THIS PRODUCT.

THE SYMBOL ON THE PRODUCT INDICATES THAT THIS PRODUCT MAY NOT BE TREATED AS HOUSEHOLD WASTE. INSTEAD IT SHALL BE HANDED OVER TO THE APPLICABLE COLLECTION POINT FOR THE RECYCLING OF ELECTRICAL AND ELECTRONIC EQUIPMENT. DISPOSAL MUST BE CARRIED OUT IN ACCORDANCE WITH LOCAL ENVIRONMENTAL REGULATIONS FOR WASTE DISPOSAL. FOR MORE DETAILED INFORMATION ABOUT TREATMENT, RECOVERY AND RECYCLING OF THIS PRODUCT, PLEASE CONTACT YOUR LOCAL CITY OFFICE, YOUR HOUSEHOLD WASTE DISPOSAL SERVICE OR THE SHOP WHERE YOU PURCHASED THE PRODUCT.