



HOOVER



USER MANUAL



PRINTED IN P.R.C.
48011753

GENERATION FUTURE

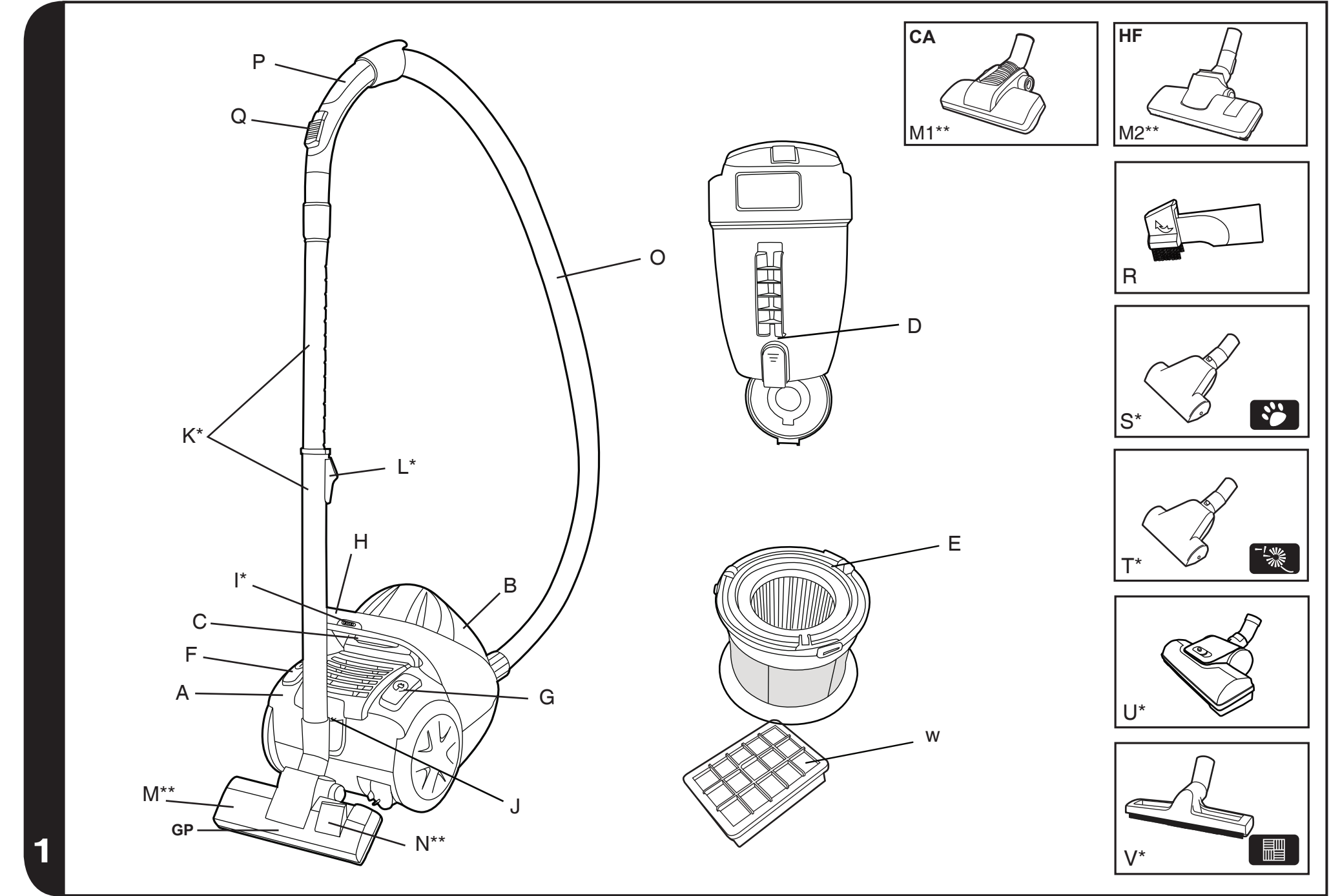

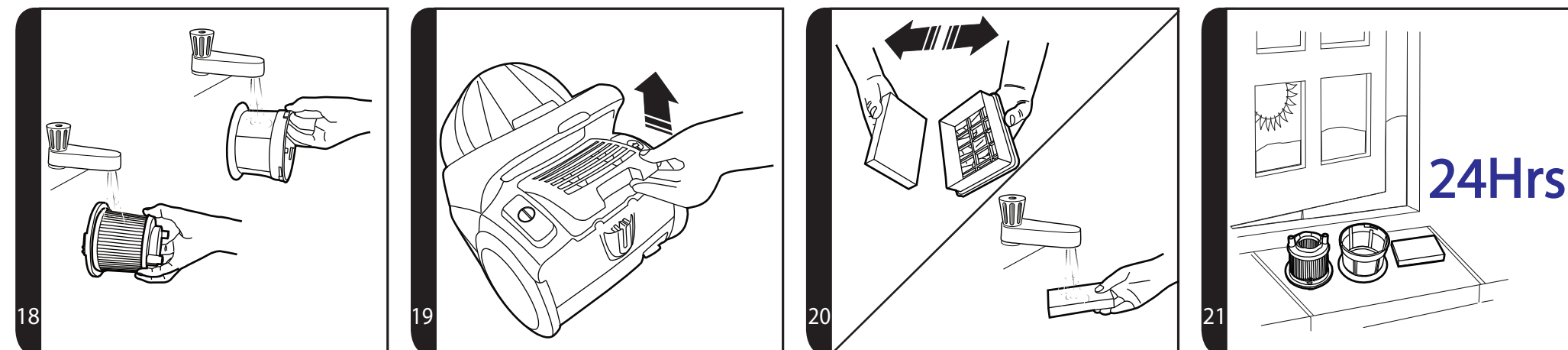
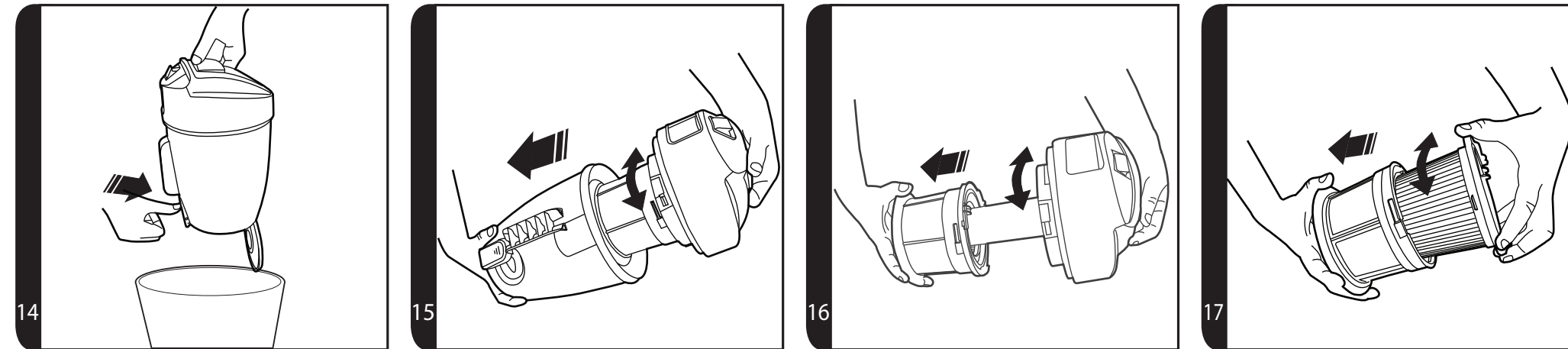
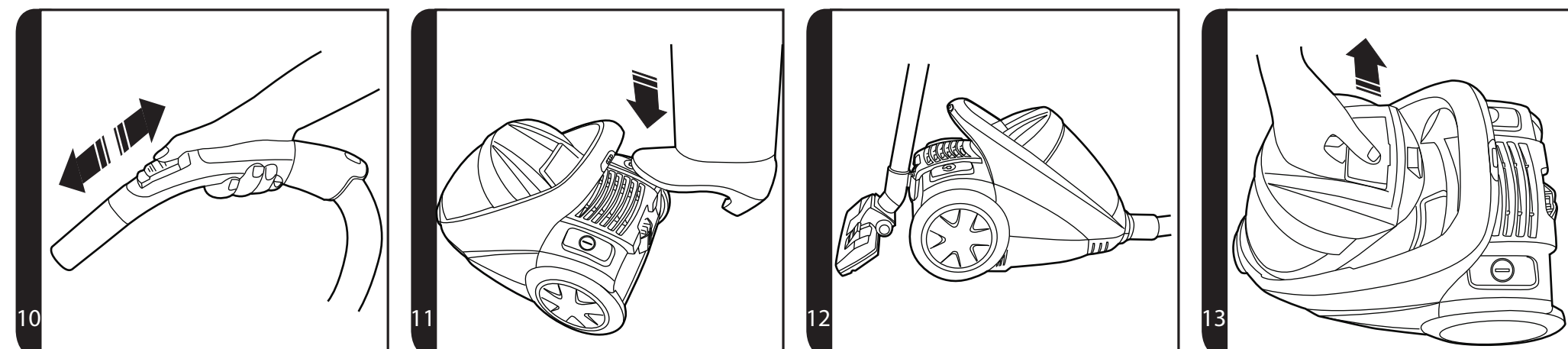
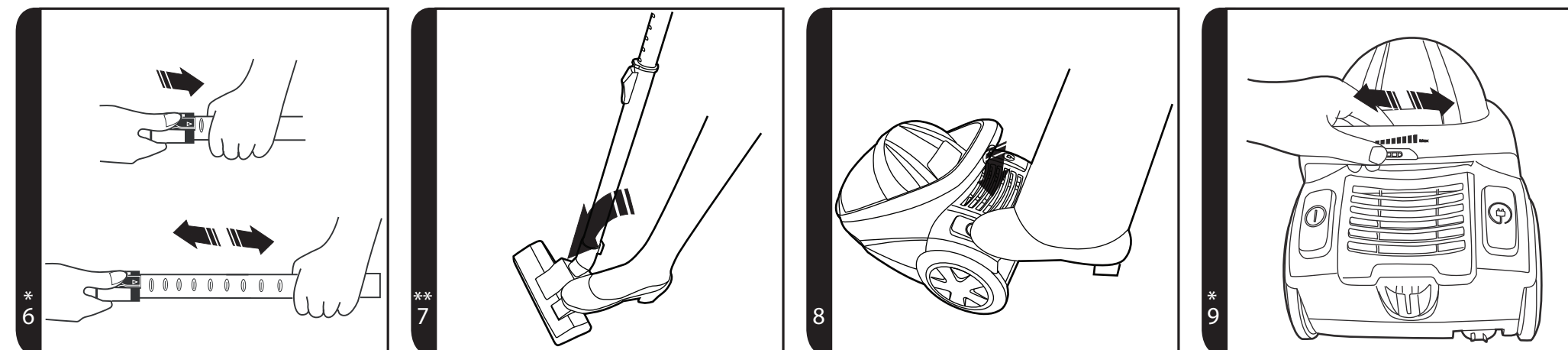
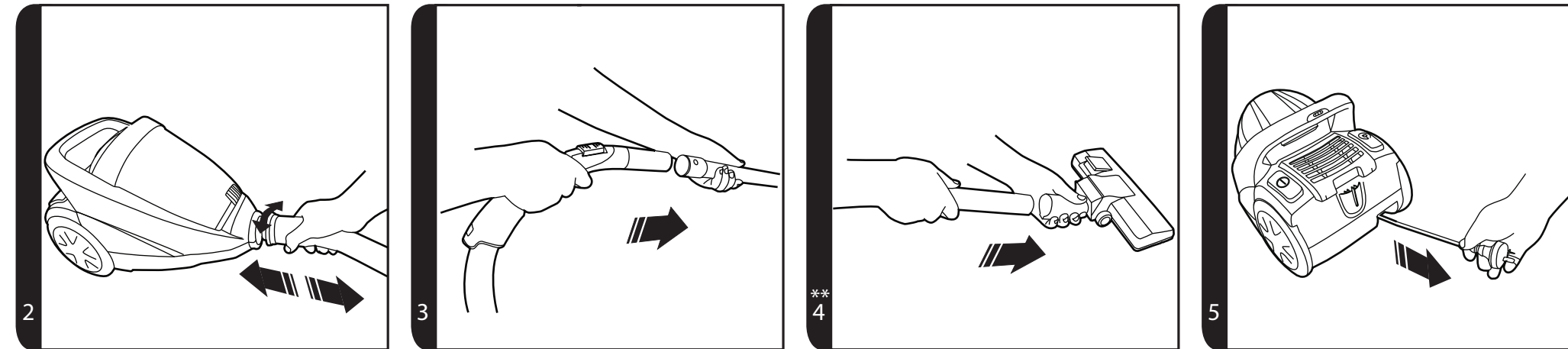

* Certain models only

** Certain models only, nozzles may vary according to model

INSTRUCTIONS FOR SAFE USE

This appliance should only be used for domestic cleaning, as described in this user guide. Please ensure that this guide is fully understood before operating the appliance.

Do not leave the appliance plugged in. Always switch off and remove the plug from the socket after use, or before cleaning the appliance or any maintenance task.

This appliance can be used by children aged from 8 years and above and persons with reduced physical, sensory or mental capabilities or lack of experience and knowledge if they have been given supervision or instruction concerning use of the appliance in a safe way and understand the hazards involved. Children shall not play with the appliance. Cleaning and user maintenance shall not be made by children without supervision.

If the power cord is damaged stop using the appliance immediately. To avoid a safety hazard, an authorised HOOVER service engineer must replace the power cord.

Keep hands, feet, loose clothing and hair away from rotating brushes.

Use only attachments, consumables or spares recommended or supplied by HOOVER.

Static electricity: Some carpets can cause a small build up of static electricity. Any static discharge is not hazardous to health.

Do not use your appliance out of doors or on any wet surface or for wet pick up.

Do not pick up hard or sharp objects, matches, hot ashes, cigarette ends or other similar items.

Do not spray with or pick up flammable liquids, cleaning fluids, aerosols or their vapours.

Do not run over the power cord when using your appliance or remove the plug by pulling on the power cord.

Do not continue to use your appliance if it appears faulty.

HOOVER service: To ensure the continued safe and efficient operation of this appliance we recommend that any servicing or repairs are only carried out by an authorised HOOVER service engineer.

Do not stand on or wrap the cord around arms or legs when using your appliance.

Do not use the appliance to clean animals or people.

Do not position the appliance above you when cleaning the stairs.

The Environment

The symbol on this appliance indicates that this appliance may not be treated as household waste. Instead it must be handed over to the applicable collection point for the recycling of electrical and electronic equipment. Disposal must be carried out in accordance with local environmental regulations for waste disposal. For more detailed information about treatment, recovery and recycling of this appliance, please contact your local city office, your household and waste disposal service or the shop where you purchased the appliance.



CE This appliance complies with the European Directives 2006/95/EC, 2004/108/EC and 2011/65/EU.

HOOVER Limited, Pentrebach, Merthyr Tydfil, Mid Glamorgan, CF48 4TU, UK

GETTING TO KNOW YOUR CLEANER

- A. Cleaner Main Body
- B. Dust Container
- C. Dust Container Release Latch
- D. Dust Container Door Release Button
- E. Pre Motor Filter Pack
- F. On/Off Button
- G. Cord Rewind Button
- H. Cleaner Carry Handle
- I. Variable Power Control Slider*
- J. Park Slot
- K. Telescopic Tube*
- L. Telescopic Tube Adjuster*
- M. Carpet and Floor nozzle **(GP)****
 - M1. Carpet Nozzle **(CA)****
 - M2. Hard Floor Nozzle **(HF)****
- N. Floor Type Selector**
- O. Hose
- P. Hose Handle
- Q. Suction Regulator
- R. 2 in 1 Tool: Ra. Crevice tool Rb. Dusting Brush
- S. Pet Hair Remover Mini Turbo Nozzle*
- T. Allergy Remover Mini Turbo Nozzle*
- U. Grand Turbo Nozzle*
- V. Hard Floor Nozzle*
- W. Exhaust Filter

ASSEMBLING YOUR CLEANER

Remove all components from the packaging.

1. Connect the hose to the cleaner main body, rotate clockwise and ensure it lo position. To release: anticlockwise the hose end and pull. **[2]**
2. Connect the handle to the tube upper end. **[3]**
3. Connect the tube lower end to carpet and floor nozzle. **[4]**

USING YOUR CLEANER

1. Extract power cord and plug it into the power supply. Do not pull the cord beyond

*Certain Models Only ** Certain models only, nozzles may vary according to model

Emptying the Dust Container the red marker. **[5]**

2. Adjust the telescopic tube* to the desired height by moving the telescopic tube adjuster* up and raise or lower the handle to the most comfortable cleaning position. **[6]**
3. Carpet & Floor Nozzle. Press the floor type selector on the nozzle **[7]** to select the ideal cleaning mode for the floor type.
 - Hard Floor** – Brushes are lowered to protect the floor.
 - Carpet** – Brushes are raised for the deepest clean.
4. Switch the cleaner on by pressing the on/off button on the cleaner main body. **[8]**
5. Adjust the power level by sliding the variable power control slider* on carry handle. **[9]**
6. Adjust the suction regulator to the desired level. **[10]**
7. Switch off at the end of use by pressing the on/off button. Unplug and press the cord rewind button to rewind the power cord back into the cleaner. **[11]**
8. To store your cleaner adjust telescopic tube* to the lowest height setting and park the nozzle in the park slot on the cleaner main body. **[12]**

ACCESSORIES

To obtain the best performance and energy efficiency ^{#1} it is recommended that the correct nozzles are used for the main cleaning operations. These nozzles are indicated in the diagrams by the letters **GP**, **HF** or **CA**.

A nozzle type **GP** can be used to clean both carpet and hard floor.

A nozzle type **HF** is suitable for use only on hard floor.

A nozzle of type **CA** is suitable for use only on carpet.

The other nozzles are accessories for specialist cleaning tasks and are recommended for occasional use only.

It is important to note that this vacuum cleaner is supplied with an Energy Label as required by European Regulation (EU) 665/2013.

If the label shows a red prohibition circle on the left covering the carpet symbol, then this indicates that the vacuum cleaner is not suitable use on carpets.

If the label shows a red prohibition circle on the right covering the hard floor symbol, then this indicates that the vacuum cleaner is not suitable for use on hard floors.

#1 NOTE: Dust pick up ability carpet, dust pick up ability hard floor, and energy efficiency in accord with Commission Regulations (EU) 665/2013 and (EU) 666/2013.

All accessories can be fitted to the end of the hose handle or the end of the tube.

2 in 1 tool – Combines several functions in one. The 2 in 1 tool can be stored neatly underneath the hose handle. **[1R]**

Crevice Tool – For corners and hard to reach areas.

Dusting Brush – For bookshelves, frames, keyboards and other delicate areas. To extend the brushes push the button on the body of the tool.

Hard Floor Nozzle* – For wooden floors and other delicate floors. [1V]

Pet Hair Remover Mini Turbo Nozzle* - Use the mini turbo nozzle on stairs or for deepcleaning on textile surfaces and other hard to clean areas. Particularly suitable for pet hairs removal. [1S]

Allergen Remover Mini Turbo Nozzle* – Use the mini turbo nozzle on stairs or for deepcleaning on textile surfaces and other hard to clean areas. Particularly suitable for allergen removal. [1T]

Grand Turbo Nozzle* – Use the turbo nozzle for deep cleaning on carpets. [1U]

IMPORTANT: Do not use the Grand turbo and mini turbo nozzles on rugs with long fringes, animal hides and carpet pile deeper than 15mm. Do not keep the nozzle stationary while the brush is rotating.

CLEANER MAINTENANCE

Emptying the Dust Container

When the dust reaches the max level indicator in the container, empty the dust container.

IMPORTANT: To maintain optimum performance do not allow the dust to sit higher than the max level.

1. Release the Dust Container by lifting the Dust Container Release Latch. Lift the Dust Container from the cleaner mainbody. [13]
2. To empty, hold the Dust Container over a bin with one hand, and use another hand to press the Dust Container Door Release Button. [14]
3. Close the Dust Container door and refit to the cleaner main body.

Cleaning the washable filters

The cleaner is fitted with a pre-motor filter pack. To maintain optimum cleaning performance regularly remove the filters and tap them against the side of bin to release dust. The filters should be washed after every 5 container empties or when the filter has excessive dust levels.

IMPORTANT: CLEAN FILTERS REGULARLY

Dirty filters affect performance, cause air blockage and motor failure. Failure to clean the filters may affect your Hoover guarantee.

1. Release the Dust Container by lifting the Dust Container Release Latch, Lift the Dust Container from the cleaner mainbody. [13]
2. Hold the Dust Container over a bin with one hand, and separate the dust bin from the dust bin lid to access the pre-motor filter pack [15]
3. Remove the filter pack by rotating it anti-clockwise from Dust Container lid. [16]

*Certain Models Only ** Certain models only, nozzles may vary according to model

4. Separate the mesh from the pre-motor filter by rotating it anti clockwise from the pre-motor filter. [17]
5. Gently tap and wash the filter and mesh, [18] Do not use hot water or detergents. Remove excess water from the filter and mesh and leave to dry fully before re-using. [21]
6. Reassemble the filter pack once fully dry and refit to the cleaner.

IMPORTANT: Always ensure the filter pack is fully dry before use.

IMPORTANT: Do not use the product without the filter pack fitted.

To access the exhaust filter:

1. Unclip the exhaust filter pack from the rear of the cleaner . [19]
2. Separate the grey foam filter from the holder. Gently tap and wash the grey foam filter using warm water.[20] Do not use hot water or detergents. Remove excess water from the filter and leave to dry fully before reusing. [21]

Removing a blockage

1. Check if the dust container is full. If so refer to 'Emptying the dust container.'
2. If the dust container is empty but suction is still low:
 - A. Do the filter need cleaning ? If so refer to 'Cleaning the washable filters'
 - B. Check if there is any other blockage in the system -Use a rod or pole to remove any blockage from the extension tube or flexible hose.
 - C. Check if pre-motor filter is filtered.

USER CHECKLIST

Should you have a problem with the product, complete this simple user checklist before calling your local Hoover service.

- Is there a working electricity supply to the cleaner? Please check with another electrical appliance.
- Is the dust container over-filled? Please refer to 'Cleaner Maintenance'.
- Is the filter blocked? Please refer to 'Cleaner Maintenance'.
- Is the hose or nozzle blocked? Please refer to 'Removing a blockage from the system'.
- Has the cleaner overheated? If so, it will take approximately 30 minutes to automatically reset. CLEANING FAQs

IMPORTANT INFORMATION

Hoover spares and Consumables

Always replace parts with genuine Hoover spares. These are available from your local Hoover dealer or direct from Hoover. When ordering parts always quote your model number.

Hoover Customer Helpline Service

Should any faults occur with your cleaner during the first 12 months contact the Hoover Customer Helpline on the number below.

Tel: 08444 995 599

Email: customer.services@hoovercandy.com

Hoover have a computerised nationwide service network of over 500 engineers who will quickly respond to your call and guarantee your repair for 12 months.

Hoover Service

Should you require service at any time, please contact your local Hoover Service Office.

Quality

Hoover's factories have been independently assessed for quality. Our products are made using a quality system which meets the requirements of ISO 9001

Your Guarantee

The guarantee conditions for this appliance are as defined by our representative in the country in which it is sold. Details regarding these conditions can be obtained from the dealer from whom the appliance was purchased. The bill of sale or receipt must be produced when making any claim under the terms of this guarantee.

Subject to change without notice.