

# HOOVER



**INSTRUCTIONS FOR USE AND INSTALLATION**  
*INDUCTION HOBS*

GB

**ISTRUZIONI D'USO E INSTALLAZIONE**  
*PIANI INDUZIONE*

IT

**INSTALLATIONS- UND BEDIENUNGSANLEITUNG**  
*CERANFELDER*

DE

**MANUAL DE UTILIZAÇÃO E DE INSTALAÇÃO**  
*PLACAS DE INDUÇÃO*

PT

**INSTRUCCIONES DE EMPLEO E INSTALACIÓN**  
*PLACAS DE INDUCCIÓN*

ES

**INSTALLATIE- EN GEBRUIKSINSTRUCTIES**  
*INDUCTIEKOOKPLAAT*

NL

**BRUGS- OG INSTALLATIONSVEJLEDNING**  
*INDUKTIONSKOGEPLADER*

DA

**KÄYTTÖ- JA ASENNUSOHJEET**  
*INDUKTIOLIESITASOT*

FIN

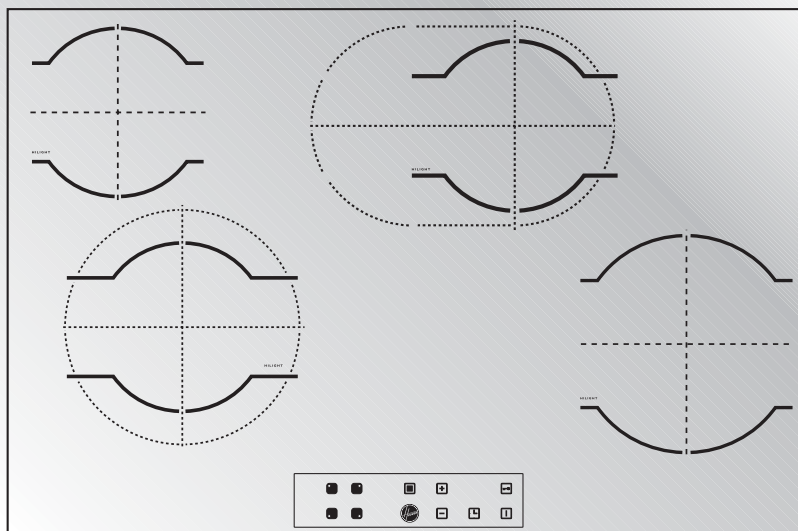

# GENERAL WARNINGS

READ THE INSTRUCTIONS BOOKLET CAREFULLY TO MAKE THE MOST OF YOUR HOB.

We recommend you keep the instructions for installation and use for later reference, and before installing the hob, note its serial number below in case you need to get help from the after sales service.

Identification plate  
(located under the hob's bottom casing)

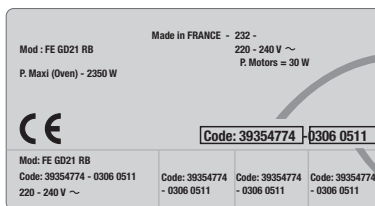

Product Code:.....  
Serial N°: .....

- It is strongly recommended to keep children away from the cooking zones while they are in operation or when they are switched off, so long as the residual heat indicator is on, in order to prevent the risks of serious burns.
- When cooking with fats or oils, take care always to watch the cooking process as heated fats and oils can catch fire rapidly.
- The hob's control area is sensitive, do not place hot containers on it.
- Aluminium foil and plastic pans must not be placed on heating zones.
- After every use, some cleaning of the hob is necessary to prevent the build up of dirt and grease. If left, this is recooked when the hob is used and burns giving off smoke and unpleasant smells, not to mention the risks of fire propagation.
- Do not left metallic objects such as knives, forks, spoons or lids on the induction zone, because if they are too large or too heavy, they could become hot
- Never cook food directly on the glass ceramic hob. Always use the appropriate cookware.
- Always place the pan in the centre of the unit that you are cooking on.
- Do not use the surface as a cutting board.
- Do not slide cookware across the hob.
- Do not store heavy items above the hob. If they drop onto the hob, they may cause damage.
- Do not use the hob as a working surface.
- Do not use the hob for storage of any items.
- In the unlikely event of a surface crack appearing, do not use the hob. Immediately disconnect the hob from the electrical power supply and call the After Sales Service.

COOKING HOB	HVI
Burners	4 INDUCTION
Supply voltage (V/Hz)	220-240/50
Installed electric power (W)	7200
Product size (l x p x h) mm.	765x517x60
Building-in dimensions (AxB)	740x490

A

B

We are constantly striving to improve product quality and as such may modify appliances to incorporate the latest technical improvements.

**CE** Glass Ceramic Hobs conform to directives 73/23/CEE and 89/336/CEE.

# INSTALLATION

Installing a domestic appliance can be a complicated operation which if not carried out correctly, can seriously affect consumer safety. It is for this reason that the task should be undertaken by a professionally qualified person who will carry it out in accordance with the technical regulations in force. In the event that this advice is ignored and the installation is carried out by an unqualified person, the manufacturer declines all responsibility for any technical failure of the product whether or not it results in damage to goods or injury to individuals.

## BUILT-IN

The furniture in which your hob will be installed and all adjacent furniture, should be made from materials that can withstand high temperatures. In addition, all decorative laminates should be fixed with heat-resistant glue.

### Installation:

- A watertight seal is supplied with the hob.

### Before fitting:

- turn the hob upside down, with the glass surface facing downwards.
- Make sure the glass is protected.**
- fit the seal round the hob.
- make sure that it is correctly fitted to avoid any leakage into the supporting cabinet.
- It is important to fit the hob on a level supporting surface.
- Deformations caused by incorrect fitting can alter the specifications of the worktop and the performance of the hob.
- Leave a gap of at least 5 cm between the appliance and any neighbouring vertical surfaces.
- It is absolutely essential that the recess conforms with the dimensions indicated.
- The height of the flush-mounted part of the hob is 5,5 cm.
- If there is an intermediate division :
  - the clearance between the bottom of the casing and an intermediate floor or part of a furniture unit must greater than 2,5 cm so as to allow air circulate.
  - The minimum distance should be 8 cm.
  - furthermore, you should ensure that there is at the rear a ventilation (8 cm) on all the width.
- **You can not build the hob in above an oven with no fan, a dishwasher, fridge, freezer or washing machine.**

- The body of the hob is fitted which 4 location holes to take the fixing clamps intended to fix the hob in the unit. Place the 4 fixing clamps, **before building-in the hob**, in such a way that the hob is placed perfectly in the support unit.

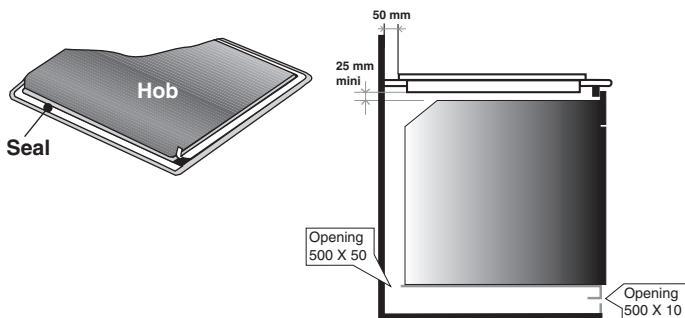

## ELECTRICAL CONNECTION

"The installation must conform to the standard directives." The manufacturer declines all responsibility for any damage that may be caused by unsuitable or unreasonable use.

### Warning :

- Always check before any electrical operation, the supply tension shown on the electricity meter, the adjustment of the circuit-breaker, the continuity of the connection to earth to the installation and that the fuse is suitable.
- The electrical connection to the installation should be made via a socket with a plug with earth, or via an omnipole cut-out switch with an opening gap of at least 3 mm.
- If the appliance has a socket outlet, it must be installed so that the socket outlet is accessible.*
- The yellow/green wire of the power supply cable must be connected to the earth of both power supply and appliance terminals.
- The manufacturer cannot be held responsible for any accidents resulting from the use of an appliance which is not connected to earth, or with a faulty earth connection continuity.
- Any queries regarding the power supply cord should be referred to After Sales Service or a qualified technician.

A power cord is not supplied with the appliance, but the hob is equipped with a terminal block which enables you to choose the correct connection for the particular power supply.

### CONNECTION TO THE TERMINALS ON THE TERMINAL BLOCK:

To proceed with the connection, you must adhere to the following instructions.

- Before making the connection, make sure that the installation is protected by a suitable fuse, see table, and that it is fitted with wires of a large enough section to supply the appliance normally.
- Choose the supply cord in accordance with the recommendations in the table.
- Turn the hob, with the glass side against the worktop, **providing you have protected the glass !**

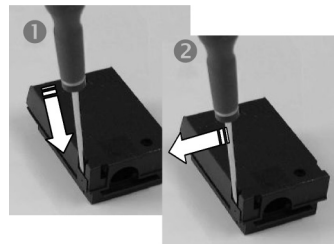

- **Open the cover in the following sequence:**

- find the two tabs located on the sides,
- put the blade of a flat screw-driver in front of each tab, push in and press,
- remove the cover.

### Connect the power supply cable:

- comply with the information of the table and the markings on the terminal board and install the shunts (the shunts, inserted in the terminal board, make a bridge between two terminals),

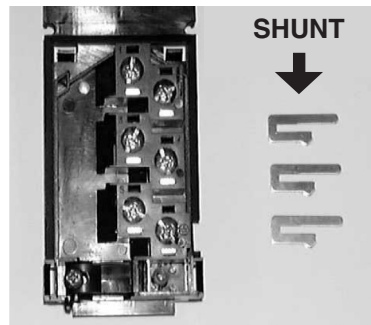

- strip the end of each conductor and attach them to the terminals, complying with the information given in the table,
- unscrew the cable clamp,
- pass the lead through the cable clamp.

When you have finished the connection operation to the appliance terminals, tighten the cable clamp and close the cover.

**Note:** make sure the terminal board screws are tight.

## ELECTRICAL CONNECTION

	MONOPHASE 230V~	THREE PHASES 400 V2-
<b>FUSE</b>	20 A	16 A
<b>CABLE</b>	H05VV-Fo H05RR-F 3 G 2,5 mm <sup>2</sup>	H05VV-F o H05RR-F 4 G 1,5 mm <sup>2</sup>
<b>CONNECTION TO THE TERMINAL BLOCK</b>	<p>Brown, Red or Black</p> <p>Blue</p> <p>Yellow/green</p> <p>CABLE H05 VV-F or H05 RR-F 3G2,5</p> <p><b>2 Phase shunt 1-2</b></p> <p><b>shunt 2-3</b></p> <p><b>5 Neutral shunt 4-5</b></p> <p><b>T Earth</b></p>	<p>Brown, Red or Black</p> <p>Blue</p> <p>Yellow/green</p> <p>CABLE H05 VV-F or H05 RR-F 4G1,5</p> <p><b>1 Phase</b></p> <p><b>3 Phase shunt 2-3</b></p> <p><b>5 Neutral shunt 4-5</b></p> <p><b>T Earth</b></p>

## INDUCTION

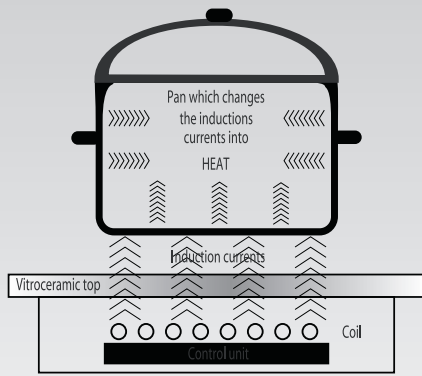

### USE PROCEDURE

An electronic generator powers a coil located inside the appliance. This coil creates a magnetic field, so that when the pan is placed on the hob, it is permeated by the induction currents. These currents make the pan into a real heat transmitter, while the glass ceramic hob remains cold. This system is designed for use with magnetic-bottomed pans

The following information will help you select the pans best adapted to obtain good results.

### INDUCTION ZONE

Mark on kitchen utensils	On the label check the mark which shows if the pan is compatible with induction 
	Use magnetic pans (enamelled iron sheet, cast-iron ferritic stainless steel) apply a magnet on the bottom of the pan (it must stick).
Stainless steel	Non detectable Excepted stainless steel ferromagnetic.
Alluminium	Non detectable
Cast-iron	Good performance Warning: can scratch the surface.
Enamelled steel	Good performance Flat, thick and smooth bottom recommended.
Glass	Non detectable
Porcelain	Non detectable
Copper bottom	Non detectable

### HOW TO OPERATE THE GLASS CERAMIC HOB

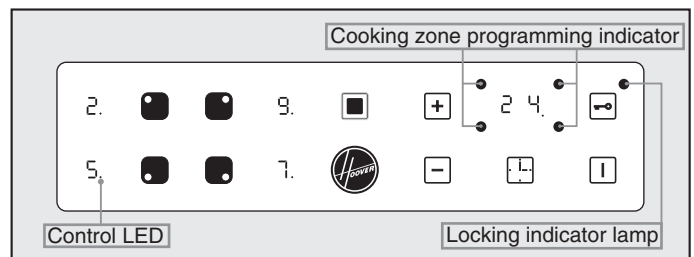

**Put simply, induction technology has two main advantages :**  
 - as heat is emitted only by the pan, heat is maintained at its maximum level and cooking takes place without any heat loss.  
 - There is no thermal inertia, as cooking automatically starts when the pan is placed on the hob and stops when it is removed.

#### A HIGH SAFETY APPLIANCE ....

If your hob is correctly installed and used, the safety devices will rarely be needed.

- **Ventilation fan** : to protect and cool the supply and control components. It has two speeds, operating automatically. The fan works even if the plates are off and this till the electronic system has enough cooled down.
- **Safety "Transistor"** : a probe checks permanently the temperature of the electronic components. If the heat is increasing excessively, it automatically decreases the power of the plates then cuts them down (the display for power level is flashing) as far as the temperature of the components meets with the standard again, the hob starts working.
- **Safety "Empty pan"** : a probe is placed under each heating area. It will immediately detect a wrong temperature for the empty pan, or the glass ceramic.
- **Safety "Detection"** : the presence detector allows the working and so the heating. A small object (eg a spoon, knife or ring) placed on the heating area will not be considered as a pan and therefore the hob will not come on.
- **Safety "Boiling over and splashing"** : if any boiling over and splashing occur, the hob will stop. If a big spill or object covers at least two buttons, for at least 10 seconds, clean up the spill or remove the object, the hob is not operating.

### HOB COOKWARE ADVICE

Using good quality cookware is critical for setting the best performance from your hob.



- **Always use good quality cookware with perfectly flat and thick bases** : using this type of cookware will prevent hot spots that cause food to stick. Thick metal pots and pans will provide an even distribution of heat.
- **Ensure that the base of the pot or pan is dry** : when filling pans with liquid or using one that has been stored in the refrigerator, ensure that the base of the pan is completely dry before placing it on the hob. This will help to avoid staining the hob.
- **Use pans whose diameter is wide enough to completely cover the surface unit** : the size of the pan should be no smaller than the heating area. If it is slightly wider the energy will be used at its maximum efficiency.

### THE DIFFERENT POSITION

The different positions correspond to the following power ratings :

Positions	INDUCTION	
	Power released in %	Maximum operation time before automatic cut off
1	2,5	10 hours
2	5	10 hours
3	7,5	5 hours
4	12,5	4 hours
5	18	3 hours
6	24	3 hours
7	45	2 hours
8	60	2 hours
9	100	1 hour
Booster according to the zone	2200 W/ 3000 W	10 minutes

For increased safety, the cooking zones cut off automatically if they are left on too long. The cut off depends on the heat level used.

#### NOTE:

The induction hob works with a generator wich supplies simultaneously 2 plates per area:

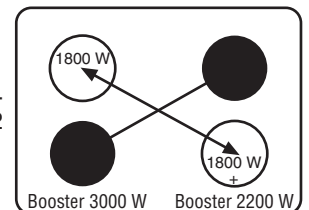



Each area take in charge a maximum power of 3600 W. Consequently, in the same area, when the Booster function is on and the second plate has reached a power level of 9 or 8 the latest is automatically decreased to the level 7 and this decrease is shown by a flashing display for information.





**Warning** : as indicated on the powers board, the Booster works during 10 minutes, after this time, it stops and the plate starts heating again at the setting 9, the power of the generator being decreased, the power level of the second plate comes back to its previous setting.



- After powering up the hob, wait 8 seconds to activate the electronic controls.

- Press the button , for 3 seconds.  
*Electronic control of the hob is activated. In each display zone the heat level  is displayed and the control LED blinks.*
- After 10 seconds without use, the electronic control goes off and the starting operation has to be repeated.

#### • STARTING A COOKING ZONE

- Press the selection button of the required cooking zone. In the display zone, the control LED is on steady. It shows that the zone is live. 
- Press the  or  button to select a heat level between 1 and 9. Hold down the  or  button and the heat level increases or decreases gradually.

The following examples are for information only. Personal experience should then let you adapt these settings to your taste and habits.

0	:	Off
1	:	)
2	:	) ..... Melting heat
3	:	Keeping hot
4	:	Heating up
5	:	Thawing, stewing, full cooking, low temperature cooking
6	:	Cooking without lid
7	:	Frying, meat browning and roasting
8	:	High temperature cooking and roasting, seizing
9	:	Frying
Booster	:	Boiling large quantities of liquids...

#### • ACTIVATION OF THE BOOSTER FUNCTION

The booster function allows to get by a simple pressure the cooking zone working with a power of 2200 W or 3000 W according to the zone, for 10 minutes period. Ideal to bring to the boil large quantities of liquids ...

##### Activation of the BOOSTER function :

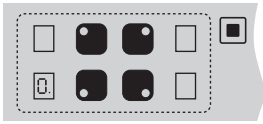
- Press the setting key of the cooking zone fitted with the booster function.   
*The control led is displayed.*

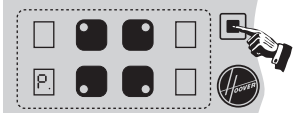
- Press the key to start the Booster. The Booster is active for 10 minutes.   
*The P mark (power) appears.*

When the time is over, the power level decreases to 9. A pressure on the key  cancels the booster function, and the power level decreases

#### • PAN DETECTOR

When the hob is operating, the pan detector provides the advantage of automatically stopping or starting the heat of the cooking zone in contact with or on removal of the pan. If therefore offers energy savings.







**If the cooking zone is used with a suitable pan\*** : the display shows the heat level or  when the booster is operating.  
\* The induction needs pans compatibles so fitted with magnetic-bottomed, see table at page 3 and pans big enough to fully cover the zone.

**If the cooking zone is used without a pan or with an unsuitable pan** : the display shows . The zone does not start. If no pan is detected after 10 minutes, the starting operation is cancelled.

#### IMPORTANT:

To stop the cooking zone, you must stop the hob normally, you cannot just remove the pan. The pan detector does not work as the hob on/off button.



#### • STOPPING A COOKING ZONE

- Press the selection button of the required cooking zone.
- Press the  button to display heat level . Now the zone goes off, the indicator  goes off after 10 seconds.
- To stop rapidly, press the  and  buttons at the same time. The heat level automatically goes down to . The cooking zone goes off.

#### • GENERAL STOP

The cooking zones and the timer can be stopped at any moment by pressing for 3 seconds on the On-Off button. 

#### • RESIDUAL HEAT INDICATOR

The control panel tells the user when the surface temperature of the cooking zones exceeds about 60°C, by the following displaying: . When the temperature goes back below 60°C, the  display goes off.

For ending the cooking, we advise switching off the cooking zone and using the residual heat of the zone to finish cooking gently.

N.B. After a cut in the current, the residual heat indicator disappears completely, even if the surface temperature exceeds 60°C.

#### • PROGRAMMING A COOKING ZONE

Every cooking zone can be programmed for a maximum time of 99 minutes. Only one zone, at a time, can be programmed.

- Start the required zone by following the previous instructions. The control LED near the heat level must be displayed, it shows that the zone is live.





- Press the Timer button. 

The zone mark around the timer display shows the controlled zone.

- Press the  button to select the time in minutes.

This is saved automatically after three seconds.

- ➔ The programmed time can be modified at any moment by pressing the timer selection button, the timer control LED must be on. When the time has run, the cooking zone goes off automatically and an audible beep sounds for 1 minute. Press any button to stop it.

- ➔ The programmed time can be reset to  using the  button or pressing the  and  buttons at the same time, the cooking zone is then no longer linked to the timer but stays operational. So you will have to stop the zone independently.

- ➔ The timer can be used alone as a reminder, it will ring at the end of the programmed time.

#### • LOCKING BUTTON OPERATION

The locking function holds the current settings, or prevents anyone from starting the hob. It is also used for cleaning the control strip as the controls can be locked without the hob being on.

- Start the required cooking zones.
- Select a heat level for each of them.
- Press the  button to set the data; in this way no other button works, except the On/Off button.

The locking indicator lamp  comes on.

- ➔ To release the locking function, just press the  button; the indicator lamp goes off, all the controls work again.

If when the controls are locked, the timer is on, the time will be counted automatically and the zone switched off at the end of the programmed time.

If the locking control is on when the hob is finally shut down, the locking control stays operational and prevents any action when the hob is restarted, press the  button to release the locking function.

## CLEANING AND MAINTENANCE

- Before carrying out any maintenance work on the hob, allow it to cool down.
- Only products, (creams and scrapers) specifically designed for glass ceramic surfaces should be used. They are obtainable from hardware stores.
- Avoid spillages, as anything which falls on to the hob surface will quickly burn and will make cleaning more difficult.
- It is advisable to keep away from the hob all substances which are liable to melt, such as plastic items, sugar, or sugar-based products.

### MAINTENANCE:

- Place a few drops of the specialised cleaning product on the hob surface.
- Rub any stubborn stains with a soft cloth or with slightly damp kitchen paper.
- Wipe with a soft cloth or dry kitchen paper until the surface is clean.

### If there are still some stubborn stains:

- Place a few more drops of specialised cleaning fluid on the surface.
- Scrape with a scraper, holding it at an angle of 30° to the hob, until the stains disappear.
- Wipe with a soft cloth or dry kitchen paper until the surface is clean.
- Repeat the operation if necessary.

### A FEW HINTS:

Frequent cleaning leaves a protective layer which is essential to prevent scratches and wear. Make sure that the surface is clean before using the hob again. To remove marks left by water, use a few drops of white vinegar or lemon juice. Then wipe with absorbent paper and a few drops of specialised cleaning fluid. The glass ceramic surface will withstand scraping from flat-bottomed cooking vessels, however, it is always better to lift them when moving them from one zone to another.

NB:

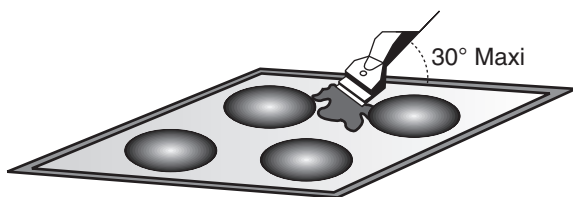

Do not use a sponge which is too wet.

Never use a knife or a screwdriver.

A scraper with a razor blade will not damage the surface, as long as it is kept at an angle of 30°.

Never leave a scraper with a razor blade within the reach of children.

Never use abrasive products or scouring powders.

## AFTERCARE

Before calling out a Service Engineer please check the following:

— that the plug is correctly inserted and fused;

If the fault cannot be identified:

switch off the appliance — do not tamper with it — call the Aftercare Service Centre. The appliance is supplied with a guarantee certificate that ensures that it will be repaired free of charge at the Service Centre.

## PROBLEM SOLVING

**The induction hob gives shorings out.**

• Normal. The cooking fan of the electronic components is on.

**The induction hob gives a light whistling out.**

• Normal. According to the working frequency of the inductors, a light whistling can occur when using several cooking zones on maximum power.

**Cooking zones that do not maintain a rolling boil or a fast enough frying rate.**

- You must use pans which are absolutely flat. If light is visible between the pan base and a straight edge, the surface unit will not transfer heat properly.
- Pan bottoms should closely match the diameter of the heat zone selected.

**Foods cook slowly.**

- Improper cookware being used. Pan bases should be flat, fairly heavy-weight and the same diameter as the heat zone selected.

**Tiny scratches (may appear as cracks or abrasions) on the glass surface of the hob.**

- Incorrect cleaning methods, cookware with rough bases, or coarse particles (salt or sand) trapped between the cookware and the surface of the hob.

Use recommended cleaning procedures, be sure cookware bases are clean before use and use cookware with smooth bases.

**Metal markings (may appear as scratches).**

- Do not slide aluminium cookware across the surface. Use recommended cleaning procedure to remove marks.
- Incorrect cleaning materials have been used, spillage or grease stains remain on the surface, use a razor scraper and recommended cleaning product.

**Dark streaks or specks.**

- Use a razor scraper and recommended cleaning product.

**Areas of discoloration on cooktop.**

- Marks from aluminium and copper pans as well as mineral deposits from water or food can be removed with the cleaning cream.

**Hot sugar mixtures / plastic melted to the surface.**

- See the Glass Hob Cleaning section.

**The hob is out of order, or some heat zones do not work.**

- The shunt bars are not properly fitted on the terminal block. Check the connection is made in conformity with the instructions page 2.

**The hob does not operate.**

- A big spill or object covers at least two buttons, for at least 10 seconds. Clean up the spill or remove the object.
- The control panel is locked. Press the “Locking” button to release.

**The hob does not cut off**

- The control panel is locked. Press the “Locking” button to release. Refer to the section, page 4.

**The hob stops automatically**

- A spill covers at least two buttons for more than 10 seconds; the hob switches to safety, and an audible beep sounds so long as the buttons are covered. Clean up the spill or remove the object.
- The cooking zones stop automatically if they are left on for too long. Refer to the section, page 3.

**Frequency of on/off operations for cooking zones**

- The on-off cycles vary according to the required heat level:
  - low level: short operating time,
  - high level: long operating time.

**“H” display, residual heat indicator, blinking**

- The electronic temperature is too high. A technician should verify the fitting in compliance with the recommendations, page 2.



This appliance is marked according to the European directive 2002/96/EC on Waste Electrical and Electronic Equipment (WEEE). By ensuring this product is disposed of correctly, you will help prevent potential negative consequences for the environment and human health, which could otherwise be caused by inappropriate waste handling of this product. The symbol on the product indicates that this product may not be treated as household waste.

Instead it shall be handed over to the applicable collection point for the recycling of electrical and electronic equipment. Disposal must be carried out in accordance with local environmental regulations for waste disposal.

For more detailed information about treatment, recovery and recycling of this product, please contact your local city office, your household waste disposal service or the shop where you purchased the product.

## AVVERTENZE GENERALI

LEGGERE ATTENTAMENTE LE ISTRUZIONI INCLUSE IN QUESTO LIBRETTO. Vi danno importanti indicazioni sulla sicurezza d'installazione, d'impiego e di pulizia, ed anche qualche consiglio per un'ottimale utilizzo del piano di cottura. Conservare con cura questo documento per consultazione ulteriore e notare qui sotto, prima dell'installazione del piano, il numero di serie dell'apparecchio, nel caso di un'ulteriore richiesta d'intervento del servizio di assistenza.

Placca segnaletica  
(situata sotto la cassetta inferiore del piano)

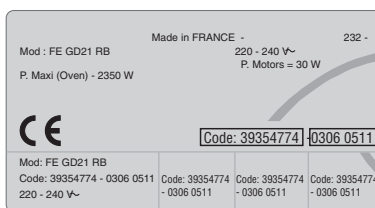

Codice prodotto : .....  
Numero di serie : .....

- Tutti le parti accessibili sono calde durante il funzionamento del piano, tenere lontano i bambini durante il funzionamento del prodotto e fino a quando non si spegneranno le spie di calore residuo.
- La carta stagnola e i recipienti in materia plastica non devono essere appoggiati sulle superfici calde.
- Si raccomanda di non depositare oggetti metallici o coperchi sul piano (il metallo é conduttore e assorbe il calore).
- Non cucinare mai direttamente sul piano, utilizzare sempre le pentole.
- Appoggiare sempre la pentola ben centrata sul bruciatore da utilizzare.
- Non utilizzare la superficie vetroceramica né come piano per tagliare né come piano di lavoro.
- Non far scivolare le pentole sul piano: rischio di graffiature.
- Non appoggiare oggetti pesanti sul piano, potrebbero cascare e rovinare il piano.
- Non lasciare oggetti depositati sul piano di qualunque tipo essi siano.
- Nel raro caso che possa esserci un'incrinatura sotto il piano in vetroceramica, staccare immediatamente l'apparecchio dall'alimentazione, e chiamare direttamente il Servizio Assistenza.

PIANO COTTURA	HVI
Bruciatori	4 INDUZIONE
Tensione alimentazione (V/Hz)	220-240/50
Potenza elettrica installata (W)	7200
Dimensioni prodotto (l x p x h) mm.	765x517x60
Dimensioni foro incasso (AxB)	740x490

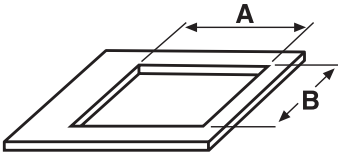
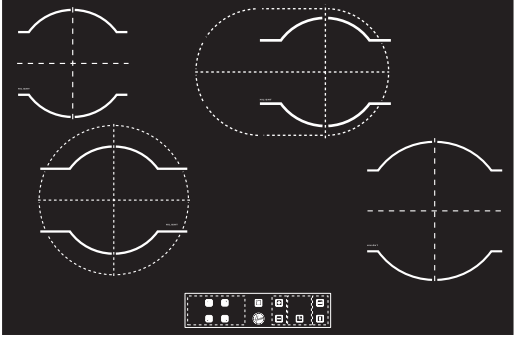
Tutte queste caratteristiche sono indicative, il produttore non è responsabile per errori di stampa. Perseguendo una politica di aggiornamento tecnico-qualitative, il produttore si riserva il diritto di apportarvi modifiche migliorative, rispettando le norme vigenti.

**CE DICHIARAZIONE DI CONFORMITÀ:** Questa apparecchiatura, nelle parti destinate a venire a contatto con sostanze alimentari, È conforme alla prescrizione della Direttiva CEE 89/109 e al D.L. di attuazione n° 108 del 25.01.92. Apparecchio conforme alle Direttive Europee 89/336/CEE, 73/23/CEE e successive modifiche.