

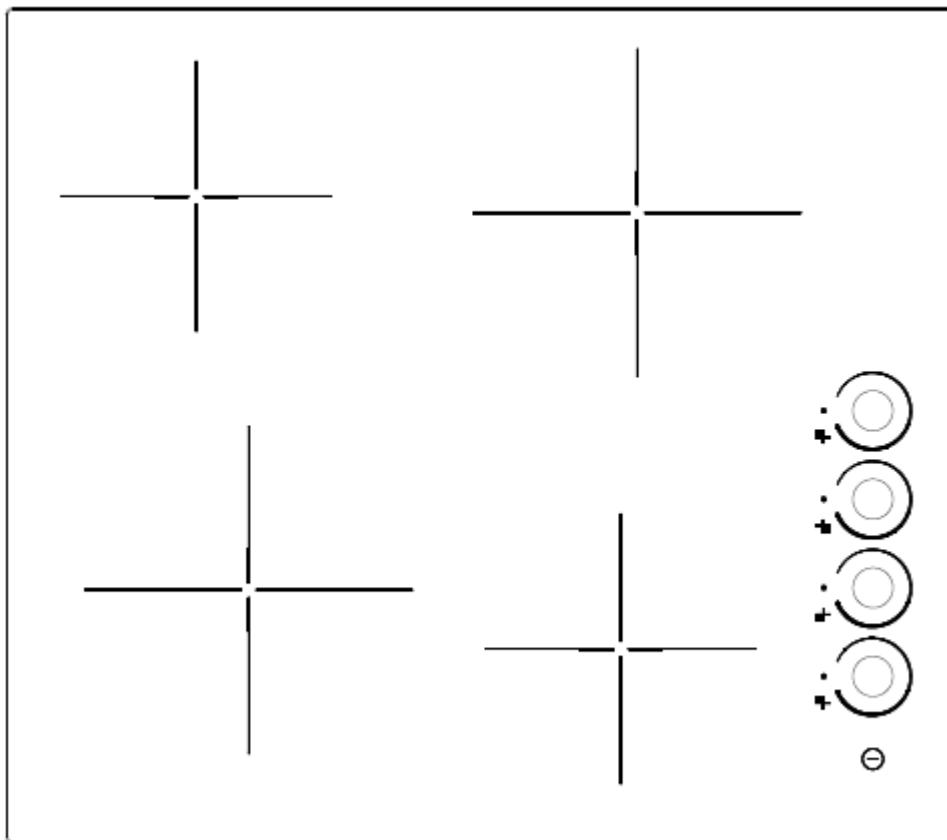

HHK64C
Ceramic Hob
Instruction Manual



Content

1.....	Safety instructions
2.....	Installation
3.....	Description of the Ceramic hob surface layout
4.....	Using the ceramic hob
5.....	Hob guidelines
6.....	Maintenance and cleaning
7.....	Environmental note

Safety instructions

This User Instruction Manual contains important information, including safety & installation points, which will enable you to get the most out of your appliance. Please keep it in a safe place so that it is easily available for future reference; for you or any person not familiar with the operation of the appliance.



Caution!

- Do not use the ceramic hob until you have read this instruction manual. The ceramic hob is intended for household use only.
- The appliance becomes hot during operation. Take care not to touch the hot surface.
- Always keep children away from the ceramic hob.
- While in operation direct contact with the ceramic hob may cause burns!
- Ensure that small items of household equipment, including connection leads, do not touch the hob as the insulation material of this equipment is usually not resistant to high temperatures.
- Do not leave the ceramic hob unattended when frying. Oils and fats may catch fire due to overheating or boiling over.
- Do not switch on the hob until a pan has been placed on it.
- Do not put pans weighing over 25kg on the hob.
- Do not use the ceramic hob in the event of a technical fault. Any faults must be fixed by an appropriately qualified and authorized person.
- In the event of any incident caused by a technical fault, disconnect the power and report the fault to the service centre to be repaired.
- The rules and provisions contained in this instruction manual should be strictly observed. Do not allow anybody who is not familiar with the contents of this instruction manual to operate the ceramic hob.
- The ceramic hob should not be cleaned using steam cleaning equipment.

- **IMPORTANT:** The adjacent furniture or housing and all materials used in the installation must be able to withstand a minimum temperature of 95°C above the ambient temperature of the room it is located in, whilst in use.
- Any damage caused by the appliance being installed in contravention of this temperature limit, or by placing adjacent cabinet materials closer than 4mm to the appliance, will be the liability of the owner.
- This appliance complies with all current European safety legislation. We do wish to emphasize that this compliance does not remove the fact that the appliance surfaces will become hot during use and retain heat after operation.

Child Safety

- We strongly recommend that babies and young children are prevented from being near to the appliance and not allowed to touch the appliance at any time.
- If it is necessary for younger family members to be in the kitchen, please ensure that they are kept under close supervision at all times.

General Safety

- This appliance is not intended for use by persons (including children) with reduced physical, sensory or mental capabilities, or lack of experience and knowledge, unless they have been given supervision or instruction concerning use of the appliance by a person responsible for their safety.
- Children should be supervised to ensure that they do not play with the appliance.
- **NEVER** try to extinguish a fire with water, but switch off the appliance

and then cover flame e.g. with a lid or a fire blanket.

- **WARNING:** Danger of fire: do not store items on the cooking surfaces.
- Means for disconnection must be incorporated in the fixed wiring in accordance with the wiring rules.
- Do not allow electrical fittings or cables to come into contact with areas on the appliance that get hot.
- Do not use the appliance to heat the room it is located in or to dry clothing.
- Do not install the appliance next to curtains or soft furnishings.
- If the supply cord is damaged, it must be replaced by the manufacturer, its service agent or similarly qualified persons in order to avoid a hazard.
- The appliance is not intended to be operated by means of an external timer or separate remote-control system.
- Power cord can't accessible after installation.
- This product can be worked but not through outside timer and remote control.
- **Warning:** If the surface is cracked, switch off the appliance to avoid the possibility of electric shock, for hob surfaces of glass ceramic or similar material which protect live parts.
- **Warning:** a steam cleaner is not be used.

- **CAUTION:** The cooking process has to be supervised. A short term cooking process has to be supervised continuously.
- **WARNING:** Unattended cooking on a hob with fat or oil can be dangerous and may result in a fire.
- This appliance should be connected to a circuit which incorporates an isolating switch which can accessible by the user after installation providing full disconnection from the power supply. The disconnection may be achieved by incorporating a switch in the fixed wiring in accordance with the wiring rules.
- **Warning:** Before obtaining access to terminals, all supply circuits must be disconnected.
- **WARNING:** Use only hob guards designed by the manufacturer of the cooking appliance or indicated by the manufacturer of the appliance in the instructions for use as suitable or hob guards incorporated in the appliance. The use of inappropriate guards can cause accidents.
- **WARNING:** The appliance and its accessible parts become hot during use.
- Care should be taken to avoid touching heating elements.
- Regarding the instructions for how to Installation, thanks to refer to the section "Installation".

Installation

Electrical connection

Before connecting the appliance, make sure that the supply voltage marked on the Rating Plate corresponds with your mains supply voltage.

WARNING: THIS APPLIANCE MUST BE EARTHED.

- If you have to change the oven power cord, the earthing (yellow/green) conductor must always be 10 mm longer than the line conductors.
- Care must be taken to ensure that the temperature of the mains supply cable does not exceed 50°C.
- If the mains supply cable is damaged, then it must be replaced by an appropriate replacement which can be obtained from Spares Department.

Assembly of ceramic hob :

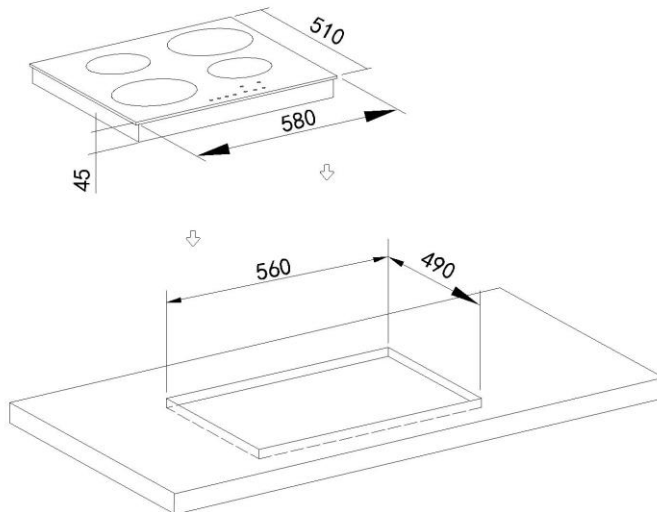

Preparing the unit for a built-in appliance

WARNING

- ✚ The kitchen units that are in direct contact with the appliances must be heat-proof(min. 95°).
- ✚ The appliance can be installed on a work surface with a thickness of between 30 and 40 mm and near to walls which are higher than the work surface,maintaining a minimum distance of 100 mm.
- ✚ Carry out all cutting of the unit and work surface then carefully remove shavings or sawdust before inserting the appliances.
- ✚ To ensure a correct ventilation of the hob please comply with the dimensions shows in figures .
- ✚ Always refer to the manufacturer for specific instructions,
- ✚ Make sure the surface is level and square and that no part interferes with the space required for installation.
- ✚ Prepare the cut as indicated(see installation dimensions).

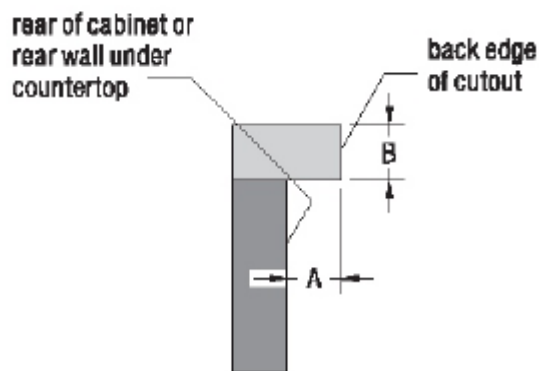
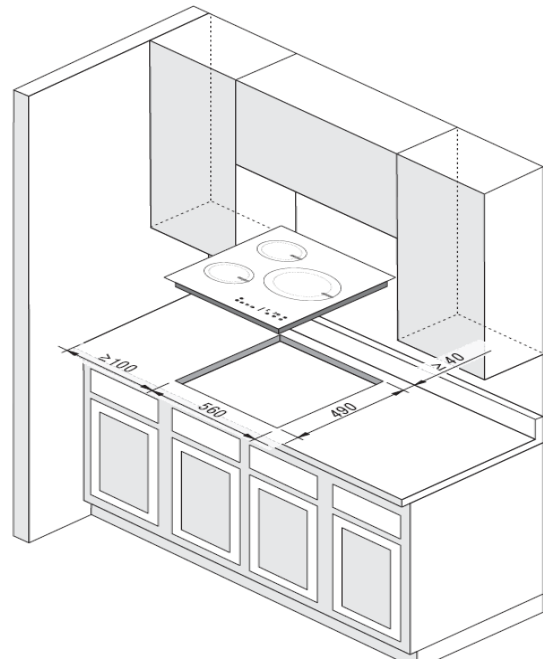

Fig.5

A. 40mm min
B. 40mm max



Installing the hob



WARNING

Risk of cutting.
Be careful of cutting edges.
End parts in foamed plastic - be careful.
During transportation these could cause slight injury or cuts.

Remove the material and envelope of documents from the packaging.
Before proceeding with installation read the work instructions carefully.

Step.1

Put a towel or cloth on the work surface. Place the hob face down on the protected surface.

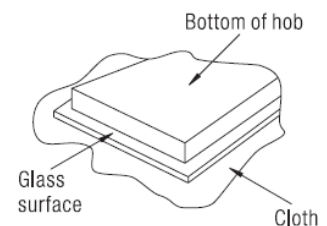

Step.2

Apply the strip seal, supplied with the hob, which is for sealing it onto the work surface.

Do not use silicone. Apply the seal to the edge of the bottom of the hob, leaving about 3mm from the edge of the glass.

Apply the seal all around the circumference.

Cut any excess and bring the two ends of the seal together so they match.

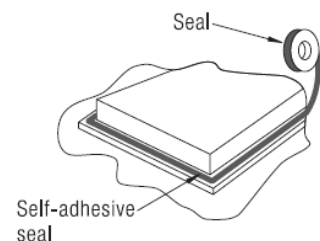

Step.3

Fix the brackets (4 pcs) on the front side and rear side by screw. Put the hob in the cut-out cabinet, and make it centered. Ensure that the front edge of the hob is parallel to the side edge of the work surface.

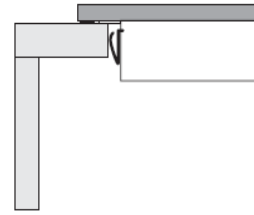
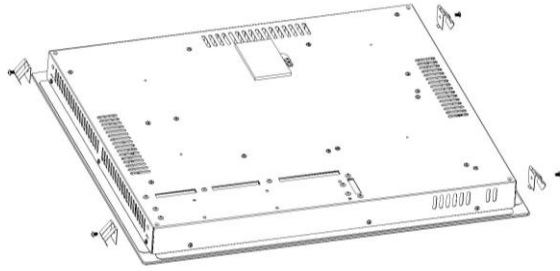

- **IMPORTANT:** You must observe the ventilation requirements shown in the drawing opposite.
- **IMPORTANT:** There are ventilation holes around the outside of the hob. YOU MUST ensure that these holes are not blocked by the work top, when you put the hob into position (see drawing opposite).
- **IMPORTANT:** Do not use a silicon sealant to seal the appliance against the aperture. This will make it difficult to remove the hob from the aperture in future, particularly if it needs to be serviced.

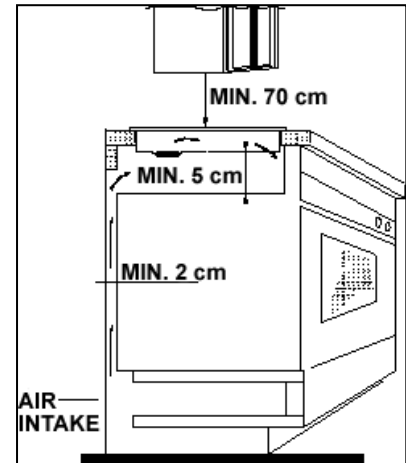

- Carefully turn the hob back over and then gently lower it into the aperture hole that you have cut out.

Fitting guidelines

The ceramic hob is manufactured to work with two-phase alternating current (400V2N~50Hz). The voltage rating of the ceramic hob heating elements is 230V. Adapting the ceramic hob to operate with one-phase current is possible by appropriate bridging in the connection box according to the connection diagram below. The connection diagram is also found on the cover of the connection box. Remember that the connection wire should match the connection type and the power rating of the ceramic hob.

The connection cable must be secured in a strain-relief clamp.

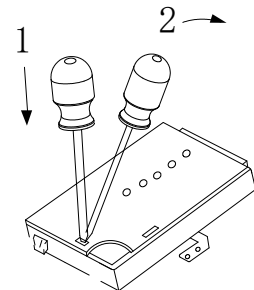

Warning!

Remember to connect the safety circuit to the connection box terminal marked with . The electricity supply for the ceramic hob must have a safety switch which enables the power to be cut off in case of emergency. The distance between the working contacts of the safety switch must be at least 3mm.

Before connecting the ceramic hob to the power supply it is important to read the information on the data plate and the connection diagram.

wires for each domino hob with 4D models			
model	Adaptive voltage range and wires		The wiring diagram
	220-240 1N~	380-420 2N~ 50-	

	50-60Hz	60Hz	
AHW-4A1-60-R	H05VV-F 3G2.5	H05VV-F 4G2.5 H05GG-F 4G2.5 H07RN-F 4G2.5	<p style="text-align: center;">CONNECTION DIAGRAM</p> <p>220-240V~ 1N H05VV-F 3G2.5</p>
			<p style="text-align: center;">KADO XT</p>
			<p style="text-align: center;">CONNECTION DIAGRAM</p> <p>380-420V~ 2N H05VV-F 4G2.5 H05GG-F 4G2.5 H07RN-F 4G2.5</p>

- The cable connections must be in accordance with the diagram located on the bottom of the hob.
- The cable type must be connected to the corresponding power supply terminal box.
- You should use a good quality screwdriver to carefully, fully tighten ALL of the terminal screws.
- If when the hob is first switched on, only two of the zones work, you should recheck that the terminal screws are all fully tightened. This should be done before contacting the Customer Care Department.
- **IMPORTANT:** The appliance must NOT be connected to the mains supply by means of a 13A plug and socket.
- This appliance must be wired into a 30 A double pole switched fused spur outlet, having 3 mm contact separation and placed in an easily accessible position adjacent to the appliance. It should not be located above the appliance and no more than 1.25m away from it.
- The cable can be looped if necessary, but make sure that is not kinked or trapped when the hob is in position. Care must be taken to avoid the cable being in contact with hot parts of the appliance.

Replacing the mains supply cable

- ✧ If the mains supply cable is damaged, then it must be replaced by an appropriate replacement.
- ✧ The mains supply cable should be replaced in accordance with the following instructions:
 - Switch the appliance off at the control switch.
 - Open the terminal block on the underside of the hob.
 - Unscrew the terminal screws fixing the cable.
 - The “green-yellow” earth wire must be connected to the terminal marked \perp . It must be about 10 mm longer than the live and neutral wires.

- The “blue” neutral wire must be connected to the terminal marked with letter (N) - the live wire(L1) must be connected to the terminal marked with letter (L1) (220-240V 1N ~).
- The “blue” neutral wire must be connected to the terminal marked with letter (N) - the live wire L1 must be connected to the terminal marked with letter (L1),. the live wire L2 must be connected to the terminal marked with letter (L2) (380-420V 2N ~).

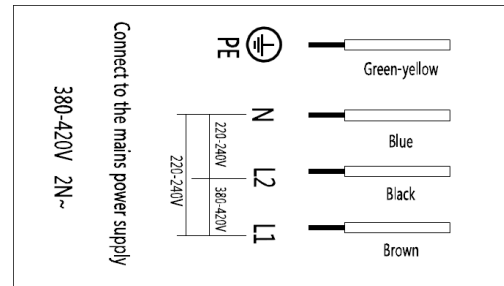
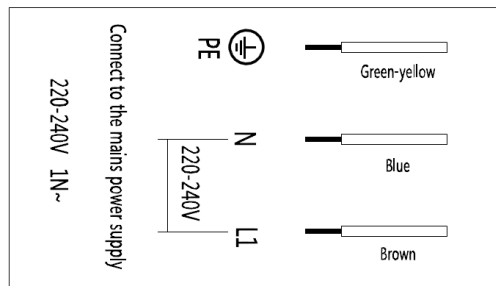

Des

cription of the Ceramic hob surface layout

4 zone ceramic hob schematic diagram

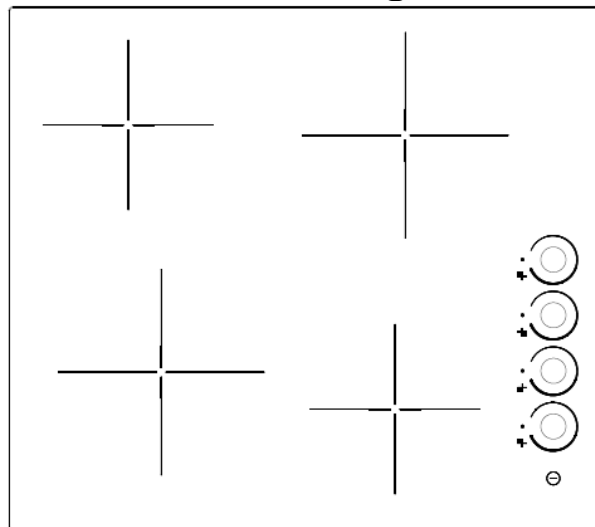

Display mode and control

1.1 Display mode

- ✓ Cooking zone working indicator: the corresponding indicator light display when the cooking zone is working;
- ✓ Cooking zone residual heat indicator: the corresponding indicator flashes when the cooking zone stops working (once every 1 second);
- ✓ The whole hob standby mode indicator: all cooking zone indicator lights alternately turn on and off .

- ✓ Touch button(power button)+ programming button(Corresponding hob top power level selecting).

1.2 Control panel

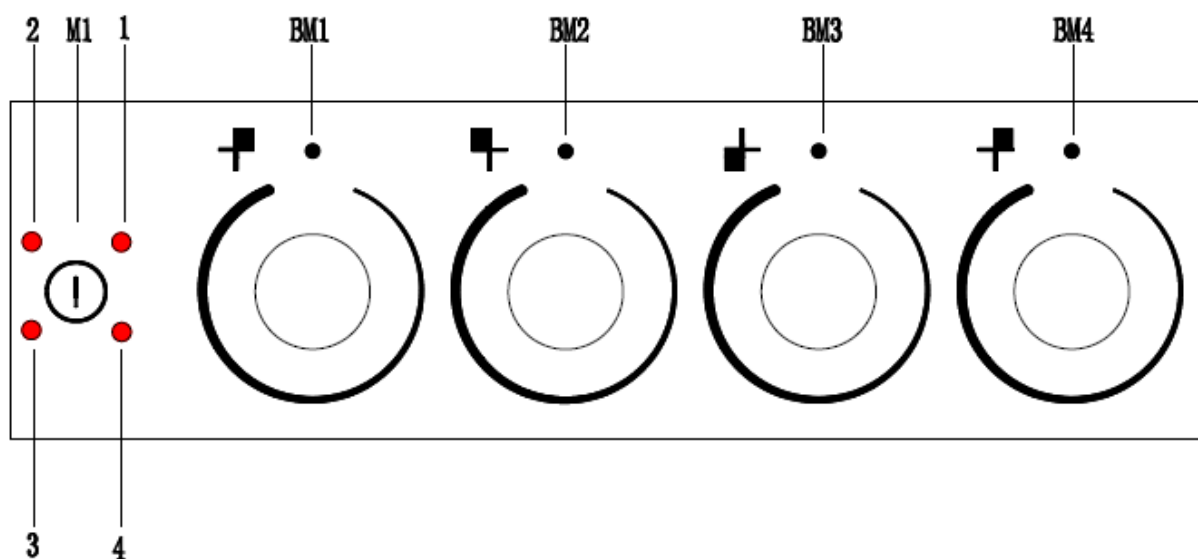

2.1 Control panel layout:

Icons & programming button	Function
M1	Power button: press and hold to turn on or off the hob
BM1	NO.1 cooking zone power level selecting
BM2	NO.2 cooking zone power level selecting
BM3	NO.3 cooking zone power level selecting
BM4	NO.4 cooking zone power level selecting

2.2 Display section

Indicator light	Function
1	NO.1 cookingzone indicating digital tube:display the power level , high temperature warning symbol etc.
2	NO.2 cookingzone indicating digital tube:display the power level , high temperature warning symbol etc.
3	NO.3 cookingzone indicating digital tube:display the power level , high temperature warning symbol etc.
4	NO.4 cookingzone indicating digital tube:display the power level , high temperature warning symbol etc.

Using the ceramic hob

Before first use



IMPORTANT: You should clean the ceramic hob surface (see “Maintenance and cleaning” section).

- ✓ You should switch on one cooking zone at a time, for 5 minutes at the maximum setting. This will help to eliminate any new smell that exists and evaporate any humidity that has formed on the heating elements during transit.
- ✓ Do not burn off more than one zone at once.
- ✓ You must place a saucepan filled half full with cold water on each zone as you burn it off.

1. Power on

- ✓ After switch on the appliance, all of the indicator digital tubes on the display screen will lit on for 2s, then the appliance goes into shutdown mode.
- ✓ Shutdown status: All the display will close except the indicator light of the heated cooking zone always on, all of display screen will be off. At this time, only the power button “ⓘ” can operated by pressing and holding, and other programming button operations are invalid.

2. Standby mode

- ✓ Under shutdown status, press and hold “ⓘ” button for 3s, all cooking zone indicator lights alternately turn on and off . The hob will enter standby mode.
- ✓ Under standby mode, if no any cooking zone heating operation, the appliance will go into shutdown status automatically after 1 minute.

3. Heating control

- ✓ Under standby mode, you can choose the cooking zone power level by pressing the programming button. In the process of adjusting the power level, clockwise rotation can increase the power level from 0 to 15(maximum), and then rotate back to “0” for a cycle; Counterclockwise rotation can be adjusted from 15 to 1 power levels, and then rotate back to “0” for a cycle.
- ✓ When the hob top is in heating status, press and hold “ⓘ” power button for 3s to switch off, and stop all the cooking zones to heat. The corresponding cooking zone indicator of the hob top which has heated before will display high temperature warning .
- ✓ Under standby mode, if some hob tops still exist residual heat, corresponding hob top indicator light will display.
- ✓ If needing to switch off one of the cooking zones, you can select corresponding the hob top's programming button to adjust the power level to “0” to switch off that zone, and will not affect the heating of the other cooking zones. When power level reaches “0”, the corresponding cooking zone indicator of the hob top which has heated before will display.

- ✓ If more than one zone is operating at the same time, total power will equal to the sum of the powers of all the working cooking zones, each cooking zone will work according to their power modulation ratio, and will not affect each other.
- ✓ You can select the appropriate output power level by rotating the programming button of the corresponding hob.
- ✓ The power level is divided into 16 levels, including the shutdown level (0 level). For the programming button, rotating clockwise to increase the power level, and rotating counterclockwise to decrease the power level. When rotating counterclockwise, if the fire power position is “0” at the beginning, you will adjust to 15 level and then reduce the level in turn.
- ✓ When switching any of the cooking zone power level to 0, it will stop the power output of that cooking zone.
- ✓ If a cooking zone has been heated, power level of all the cooking zone are “0”, the appliance will automatically enter into shutdown status after 1 minute no operation.

4. Shutdown

- ✓ Under standby mode or heating mode, press and holding “” button for 3s, the appliance will go into shutdown mode. If there is residual heat in the corresponding cooking surface at this time, the corresponding cooking zone indicator flashes, indicating a warning of residual heat.

7. Default timing

- ✓ All the cooking zones have default timing function. The relationship of default timing and power level refers to table below:

Power Level	1	2	6	4	5	6	7-15
Default timing(h)	6h	6h	5h	5h	4h	4h	1.5h

- ✓ When all the default timing is reached, the cooking zones will switch off automatically and enter into standby mode.

8. High temperature warning

- ✓ Press and hold power button “” manually for 3s till switch off, the whole appliance will stop heating, but the cooking surface still has high temperature, the indicator light of the cooking zone that stops heating flashes, indicating that the corresponding heating furnace surface is hot.
- ✓ As long as the cooking zone has heated before, the indicator light will display for 35 minutes continually after the hob turn off.

9. Protection function

- ✓ **High temperature protection:** The electronic temperature sensor on the control panel will transmit the real-time temperature to the chip of the control panel. The control sensor starts protection when the electronic temperature sensor gauge the current temperature is higher than a certain value, to reduce the heating level of

the cooking zone currently, and resumes the heating level after the temperature drops.

- ✓ **Residual heat protection:** When the whole appliance stops heating, the indicator light of the relative cooking zone will display, indicating that cooking surface temperature is too high, please do not touch to avoid getting burned.
- ✓ **Safety cut-off protection:** For the models with plug, when cut off after 1S at any time, the voltage between L/N of the plug should fall to below safe voltage range.

10. PCB board fault codes and solutions

When a PCB board failure occurs, the timer digital tubes on the display panel always display the fault code, and all the burners that are being heated stop heating, and automatically return to the shutdown state after 1 minute. For the burners that have been worked, their indicator light continue to display slowly (display 1 time per second), indicating that cooking surface temperature is too high. When the fault code appears, please refer to the scheme in the following table to solve.

Fault code	Type of fault	Solution
All indicator lights display quickly (display 0.5s/times)	The display board does not receive the signal of power supply board.	The communication line failure of power supply board or display board can cause communication anomalies.
No.1,2,3 burners indicator lights display quickly (display 0.5s/times)	The power supply board does not receive the signal of display board.	Replace the display board first. If the fault persists, replace the power supply board.
No.2,3,4 burners indicator lights display quickly (display 0.5s/times)	Power supply board relay failure	Replace the power supply board.
No.1,3 burners indicator lights display quickly (display 0.5s/times)	1.Open circuit of the display board NTC. 2.Short circuit of the display board NTC.	Replace the display board
No.2,4 burners indicator lights display quickly (display 0.5s/times)	High temperature protection on the display board NTC.	Replace the Insulated silicone strip of circuit panel first. If the fault persists, replace the display board .

How to use the hot plate

Put the pot in center of the heating zone, Turn the knob clockwise and anticlockwise to turn on the hob.

High temperature indication lamp:

When the glass plate is too hot, the high temperature indication lamp will light up, don't touch the glass plate until the indication lamp goes out.

Shut down:after using,please turn the knob to "OFF",the hob will stop heating.



wrong



wrong

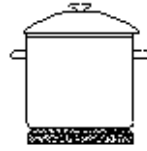

right

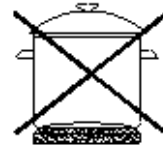

wrong

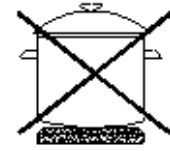

wrong

Caution!

- Ensure the heating plate is clean-a soiled zone does not transfer all of the heat.
- Protect the plate against corrosion.
- Switch off the plate against corrosion.
- Do not leave pans with prepared dishes based on fats and oils unattended on the switched-on plate; hot fat can spontaneously catch fire.

Hob guidelines

- ✧ The first few times the hob top is used, it may give off an acrid, burning smell. This smell will disappear completely with repeated use.
- ✧ The worktop is fitted with cooking areas of different diameter and power.
- ✧ The positions where the heat will radiate from are clearly marked on the hob top. The saucepans must be positioned exactly on these zones for efficient heating to occur. Pans should have the same diameter as the cooking zone that they are being used on.
- ✧ You should not use saucepans with rough bottoms, as this can scratch the ceramic surface.
- ✧ Before use, make sure that the bottoms of the saucepans are clean and dry.
- ✧ When cold, the bottom of the pans should be slightly concave, as they expand when hot and lie flat on the surface of the hob. This will allow the heat to transfer more easily.
- ✧ The best thickness for the bottom of the pans is 2 – 3 mm of enamelled steel and 4 – 6 mm for stainless steel with sandwich type bottoms.
- ✧ If these rules are not followed, then there will be a great loss of heat and energy. Heat not absorbed by the saucepan, will spread to the hob, frame and surrounding cabinets.
- ✧ Preferably cover pans with a lid to permit cooking at a lower heat.
- ✧ Always cook vegetables and potatoes, etc. in as little water to reduce cooking times.
- ✧ Food or liquid that has high sugar content may damage the hob top if it comes into contact with the ceramic hob surface. Any spillages should be wiped up immediately, however this may not prevent the hob surface from becoming damaged.
- ✚ **IMPORTANT:** The ceramic hob surface is tough; however it is not unbreakable and can be damaged. Especially if pointed or hard objects are allowed to fall on it with some force.

Maintenance and cleaning



Cleaning operations must only be carried out when the hob is cool.

The appliance should be disconnected from your mains supply before commencing any cleaning process.

Cleaning the ceramic hob top



Any residues that are left on the hob top surface from cleaning agents will damage it. You should remove any residues with warm water mixed with a little washing up liquid.



Abrasive cleaners or sharp objects will damage the hob surface; you should clean it using warm water mixed with a little washing up liquid.



You may find it easier to clean some deposits whilst the hob surface is still warm. However you should take care not to burn yourself if cleaning the hob surface when it is still warm.

After each use

- ◆ Wipe the appliance over with a damp cloth.
- ◆ Dry the appliance by rubbing the surface with a clean cloth.

Cleaning table

Type of deposit	Remove immediately?	Remove when the appliance has cooled down?	What should I use to remove the deposit?
Sugar or food/liquid containing sugar	Yes	No	Ceramic hob scraper
Tin foil or plastic	Yes	No	Ceramic hob scraper
Fat splashes	No	Yes	Ceramic hob cleaner
Metallic discolouration	No	Yes	Ceramic hob cleaner
Water splashes or water rings	No	Yes	Ceramic hob cleaner

Important!

The inside of the hob should only be washed with warm water and a small amount of washing-up liquid.

Caution!

Ensure the heating plate is clean-a soiled zone does not transfer all of the heat.

Protect the hob against corrosion.

Switch off the hob against corrosion.

Do not leave pans with prepared dishes based on fats and oils unattended on the switched-on plate; hot fat can spontaneously catch fire.



IMPORTANT: If your appliance appears not to be operating correctly, Please contact with dealer.

DO NOT ATTEMPT TO REPAIR THE APPLIANCE YOURSELF.

Please note that if an engineer is asked to attend whilst the product is under guarantee and finds that the problem is not the result of an appliance fault, then you may be liable for the cost of the call out charge.

The appliance must be accessible for the engineer to perform any necessary repair. If your appliance is installed in such a way that an engineer is concerned that damage will be caused to the appliance or your kitchen, then he will not complete a repair.

Environmental note

Note: Before discarding an old appliance, switch off and disconnect it from the power supply. Cut off and render any plug useless. Cut the cable off directly behind the appliance to prevent misuse. This should be undertaken by a competent person.

This appliance is marked according to the European directive 2002/96/EC on Waste electrical and Electronic Equipment (WEEE). By ensuring this product is disposed of correctly, you will help prevent potential negative consequences for the environment and human health, which could otherwise be caused by inappropriate waste handling of this product.

The symbol  on the product or on the documents accompanying the product indicates that this appliance may not be treated as household waste. Instead it shall be handed over to the applicable collection point for the recycling of electrical and electronic equipment.

Disposal must be carried out in accordance with local environmental regulations for waste disposal. For more detailed information about treatment, recovery and recycling of this product, please contact your local city office or local waste management office.

The packaging materials that we use are environmentally friendly and can be recycled. Please discard all packaging material with due regard for the environment.

