



SPRINT

GENERATION FUTURE



ENGLISH	GB
FRANÇAIS	FR
DEUTSCH	DE
ITALIANO	IT
ESPAÑOL	ES
PORTUGUÊS	PT
VLAAMS/NEDERLANDS	BE/NL
DANSK	DK
SUOMI	FI
Česky	CZ
POLSKI	PL
Русский	RU
SVENSKA	SE
NORSK	NO
Türkçe	TR
Ελληνικά	GR
عربي	AR

USER INSTRUCTIONS

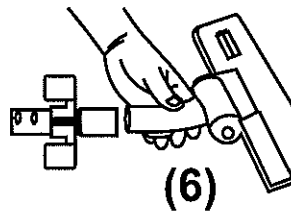
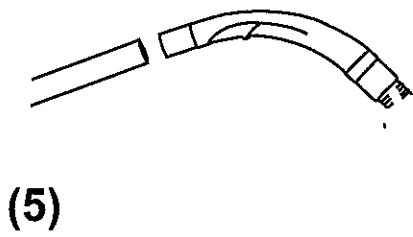
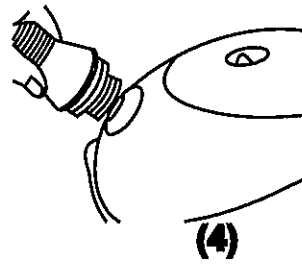
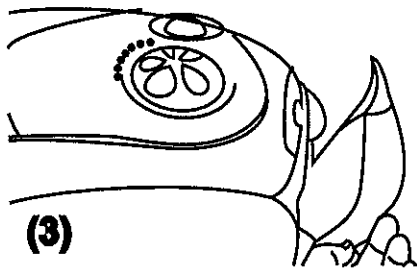
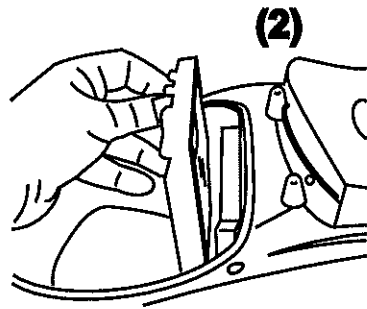
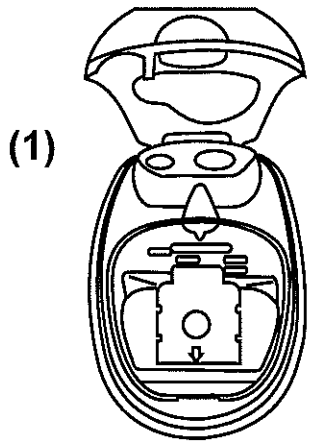

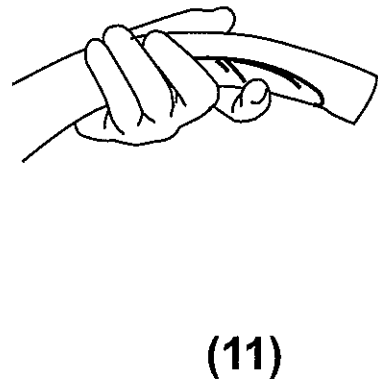
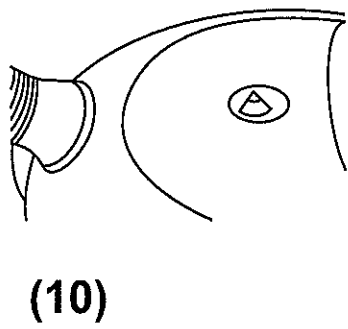
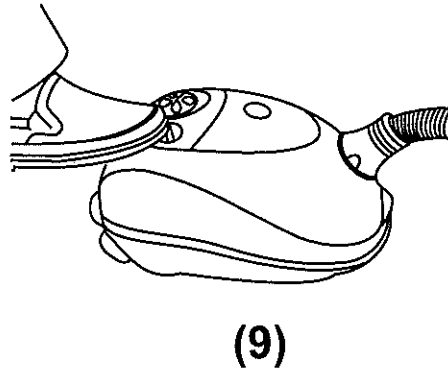
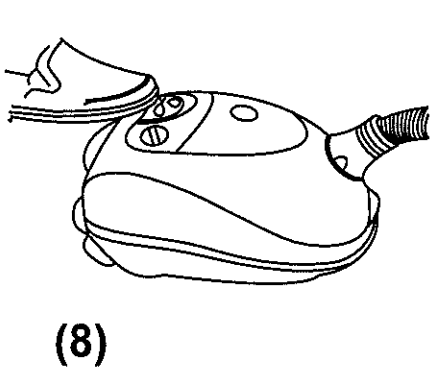
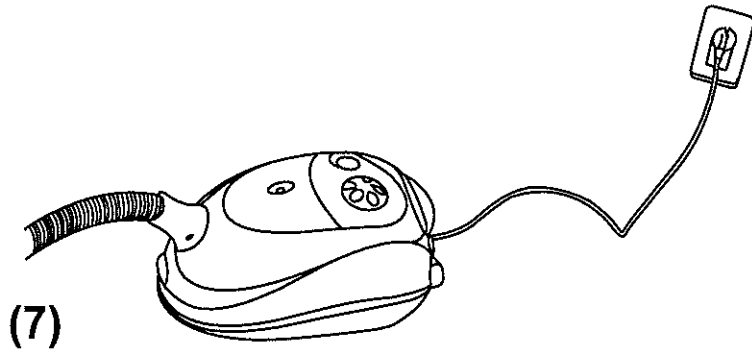

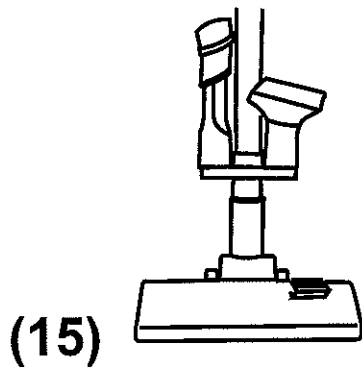
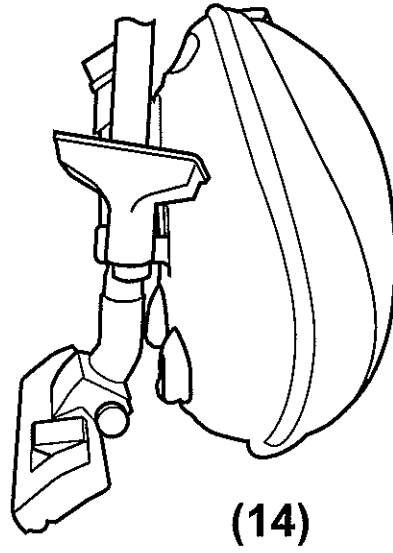
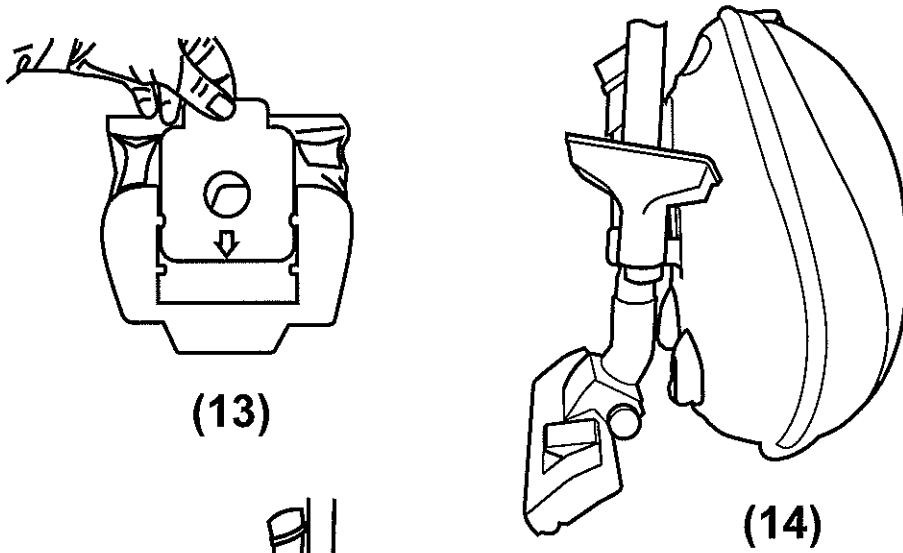
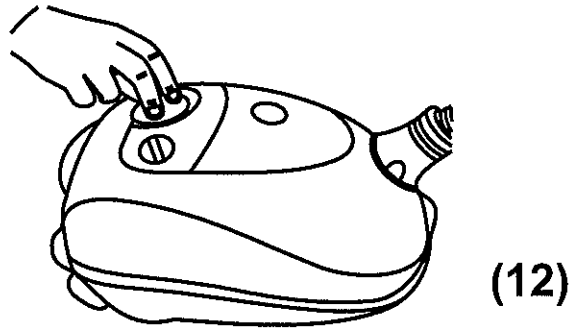



IMPORTANT SAFETY REMINDERS

This cleaner should only be used for domestic cleaning as described in these instructions. Please ensure that these are fully understood before operating this appliance. This product is double insulated and must not be earthed.

IMPORTANT: The wires in the power cord are coloured in accordance with the following code:

Blue - Neutral

Brown - Live

13 Amp fused plug on UK versions only.

GETTING STARTED

By following this step-by-step guide your new Hoover cleaner will be ready for use:

Remove cleaner and accessories from packaging. Please dispose of the packaging in a safe and environmentally conscientious way.

Open the top cover (1) ensuring that the bag, pre-motor filter (2) and exhaust filter (3) are fitted correctly. Close the top cover.

Insert the hose end into the top cover, ensuring it clips and locks into position (4). To release simply press in the two latches and pull.

Fit extension tube (5), floor nozzle (6), and other accessories as required for use.

Your cleaner is now ready for use. Extract the plug and pull out all of the cord. Plug in and switch on. (7)

FEATURES

On/Off button (8). Once plugged in, press this button to start the cleaner. Press it again to stop the cleaner before removing the plug after use.

Cord rewind button (9). Remove the plug from the power supply. Press this button to wind the power cord back into the cleaner.

Bag Check Indicator. (10)

When activated this device warns that the bag requires to be replaced or emptied. Please refer to chapter, "Replacing the bag / Emptying permanent bag".

If after changing the paper bag or emptying the Permanent bag the Bag Check Indicator is still activated, a blockage has occurred. Please refer to chapter "Removing a blockage from the system".

Fixed power control (depending on model). Adjust the suction by moving the hose handle valve (11): suction will decrease when opening the valve. Use low suction for delicate fabrics.

Variable power control (12) (depending on model). Rotate the control to increase or decrease suction. Use low suction for delicate fabrics.



Carpet and floor nozzle (6). Press pedal on the nozzle to lower the brush head when cleaning hard floors. Press the pedal again to lift the brush head when cleaning carpets.

Dual function tool. Tool is stored on the Tool Holder (15) which is fixed to the Extension Tube. Remove tool and use as:

a) Dusting brush for furnishings, bookshelves, frames, keyboards etc.
b) Crevice tool [detach the dusting brush] for corners and hard to reach areas.

c) A Furniture Nozzle is also stored on this Holder Tube Storage (14). The tubes can be stored into the storage slot underneath of the cleaner.

REPLACING THE BAG/EMPTYING THE PERMANENT BAG

REPLACING THE BAG (depending on model):

When full (See " Bag Check Indicator" paragraph) please dispose of the bag immediately.

Open the top-cover and grip the bag holder. Lift the bag holder vertically out of the cleaner and remove the Bag from its holder (13).

Dispose of the full bag into a bin.

Fold and fit new bag into the bag holder (13). Replace the bag holder into the cleaner.

Use only genuine Hoover bags.

EMPTYING THE PERMANENT BAG (depending on model):

When full (See " Bag Check Indicator" paragraph) please empty the bag immediately.

Open the top-cover and grip the bag holder. Lift the bag holder vertically out of the cleaner.

Remove the Permanent Bag from the bag holder (13).

Remove the plastic slide at the end of the bag allowing dirt collected to fall into the bin

Refit the slide back into its original position.

Fit the empty Permanent bag into the bag holder (13). Replace the bag holder into the cleaner (1).

Check filters for excessive build up of dust. If required, clean or replace. Close the top-cover. See diagrams (2 & 3) to access the filters.

To maintain best performance we recommend you wash the filters and the Permanent bag (depending on model) after 5 full bags. Please refer to chapter "FILTERS AND PERMANENT BAG MAINTENANCE".



FILTERS AND PERMANENT BAG MAINTENANCE

To maintain best performance we recommend that you rinse the filters and permanent bag under lukewarm water after 5 full bags

To access the filters please refer to diagrams 2 & 3

Do not scrub the filters and permanent bag and do not use detergents

Remove excess water with a dry cloth and leave to air dry until fully dry

After completing the washing operations, return the filters and permanent bag to their original positions in the cleaner.

REMOVING A BLOCKAGE FROM THE SYSTEM

The Bag Check Indicator on your cleaner is activated:

- 1) Check if the dust bag is full. If so refer to chapter "Replacing the bag / Emptying the Permanent bag".
- 2) If not full then:
 - a) Did you wash the filters and permanent bag after 5 full bags? If not please refer to chapter "FILTERS AND PERMANENT BAG MAINTENANCE".
 - b) Check if there is any other blockage in the system.

Use a rod or pole to remove any blockage from the tubes and flexible hose.

It may also be possible to remove an obstruction in the flexible hose by lightly squeezing or bending it.

Clean the underside of the carpet and hard floor nozzle frequently by using the crevice tool.

SIMPLE USER CHECK LIST BEFORE CALLING FOR SERVICE

- 1) Is there a working electricity supply to the cleaner? Check with another appliance
- 2) Is a restriction causing the bag check indicator to be activated in use? If yes:
 - a) Is the dust bag full? Please refer to chapter "Replacing the bag/ Emptying the Permanent bag".
 - b) Are the filters blocked? Please refer to chapter "Filters maintenance".
 - c) Is the hose or nozzle blocked? Please refer to chapter "Removing a Blockage from the System".

Please remember that:

- 1) Some carpets can cause a small build up of static electricity. Any static discharge is not hazardous to health or the product.
- 2) A service charge will be made if the cleaner is examined and found in working order, has not been assembled in accordance with these

GB

DO

Call your nearest Hoover Service Centre in the event of dissatisfaction.

Ensure that all service and repairs are carried out by an authorised Hoover Service Engineer.

Only use genuine Hoover parts.

Replace the paper bag or empty the Permanent bag as soon as the bag check indicator activates.

Always switch off and remove the power plug from the electricity supply after use and before cleaning the appliance or attempting user maintenance as described in these instructions.

Remember: Electricity can be dangerous.

DO NOT

Position the cleaner above you when cleaning stairs.

Use your cleaner out of doors, on wet surfaces or for wet pick up.

Pick up matches, hot ashes, cigarette ends or anything that may damage the product.

Spray with or pick up flammable liquids, cleaning fluids, aerosols or their vapours as this may cause risk of fire/explosion.

Run over, stand on, or wrap the power cord around arms or legs when using your cleaner.

Continue to use your cleaner if it or the plug/power cord appears to be faulty or damaged. To avoid safety hazards the cleaner must only be repaired by an authorised Hoover Service Engineer.

CONSUMABLE PARTS: For consumables please quote the following pack numbers.

Replacement Paper Bag pack No. H58

Guarantee Statement

The guarantee conditions for this appliance are as defined by our representative in the country in which it is sold. Details regarding these conditions can be obtained from the dealer from whom the appliance was purchased. The bill of sale or receipt must be produced when making any claim under the terms of this guarantee.

Subject to change without notice.

UK

HOOVER LTD Pentrebach,
Merthyr Tydfil, Mid Glamorgan
CF48 4TU
GIA5 Customer Service
08705 400600
Hoover Spares 01204 556111

8